

INSTITUTO TECNOLÓGICO DE COSTA RICA

VICERRECTORÍA DE INVESTIGACIÓN Y EXTENSIÓN

DIRECCIÓN DE PROYECTOS

ESCUELA DE INGENIERÍA FORESTAL

CENTRO DE INVESTIGACIÓN EN INTEGRACIÓN BOSQUE INDUSTRIA

INFORME FINAL DE PROYECTO DE INVESTIGACIÓN:

“Influencia de los nutrientes minerales, características del suelo, edad del árbol y condiciones ambientales en el color del duramen y algunas propiedades en la madera de *Tectona grandis* (TECA-COLOR)”

INVESTIGADORES:

*Ing. Roger Moya R. Ph.D.
Ing(a). Laura Leandro Z., M.Sc.
Ing. Alexander Berrocal J., M.Sc.*

OTROS INVESTIGADORES DE APOYO:

*Ing. Julio Calvo A. Ph.D.
Ing. Olman Murillo G. Ph.D.*

MAYO, 2009.



**INSTITUTO TECNOLÓGICO DE COSTA RICA
VICERRECTORÍA DE INVESTIGACIÓN Y EXTENSIÓN
DIRECCIÓN DE PROYECTOS**

**INFORME FINAL DE PROYECTO
(N° 5402-1401-9401)**

1. DATOS GENERALES

1. Nombre del Proyecto **Influencia de los nutrientes minerales, características del suelo, edad del árbol y condiciones ambientales en el color y algunas propiedades físicas del duramen en la madera de *Tectona grandis* TECA-COLOR**
2. Departamento académico o Centro responsable: Escuela Ingeniería Forestal / CIIBI.
3. Otros departamentos participantes: Ninguno.
4. Investigador(a) responsable: Ing. Roger Moya. Dr.
5. Investigadores participantes:

Nombre del(la) investigador(a) y grado académico	Jornada en el proyecto (hrs/sem)	Período	Nº de meses en el proyecto	Tipo de plaza*
Ing. Roger Moya Ph.D.	20	Enero-2007 Diciembre-2008	24	Docencia
Ing. Laura Leandro Z M.Sc.	10	Julio-2008 Diciembre-2008	6	Docencia
Ing. Alexander Berrocal J M.Sc.	10	Enero-2007 Julio-2008	18	Docencia

6. Fecha de inicio: 1° enero 2007
7. Fecha de finalización: 30 Diciembre 2008
8. Sesión y fecha de aprobación de Escuela: Sesión Extraordinaria 03-2006 (15 de mayo de 2006).

2. RESUMEN DEL PROYECTO:

Aunque el color de la madera de teca es un factor importante para su comercialización, las causas de la variación en el color son poco conocidos. Este problema no solo ocurre madera proveniente del hábitat natural, si no que también creciendo en plantaciones forestales que es altamente influenciado por las condiciones de crecimiento, el ambiente, el manejo y los suelos en las que se planta en Costa Rica. En vista de este problema es que en este proyecto de investigación se estableció con la finalidad de determinar el efecto de las condiciones ambientales, características físicas y químicas del suelo (tipo de suelo), las condiciones de la plantación en el color del albura y el duramen de la madera. Así también se relacionó la durabilidad natural de la madera proveniente de plantaciones forestales de rápido crecimiento con el color de la madera. Dentro de otros productos tenidos en este proyecto, fue determinada la influencia de las propiedades del suelo y los clones en otras propiedades de la madera.

Varios fueron los principales resultados encontrados: (i) Los aspectos físicos y químicos del suelo en general no presentan grandes efectos en las propiedades del color de la madera, ya que parece que el color está relacionado más con los aspectos climatológicos del sitio, como por ejemplo, el déficit hídrico, (ii) fue encontrado que además de que las propiedades físicas y químicas del suelo determinan el color de la madera, es posible también controlar este parámetro por otros aspectos tales como edad del árbol, tasa de crecimiento y densidad de plantación, los cuales son regulados por el manejo de las plantaciones y (ii) se encontró que los parámetros del color de la madera pueden ser controlados genéticamente, Además se encontró que el color posee un alto índice de heredabilidad, lo cual sin duda permitirá seleccionar clones con mejores características de color.

Toda la información acá presentada fue generada de plantaciones de rápido crecimiento, todas ellas con edades muy próximas al turno de rotación y la información que es generada tiene como objetivo poner a disposición del sector de reforestación costarricense, todas las características necesarias para el procesamiento industrial de las especies de plantación.

Palabras clave: *Tectona grandis*, plantaciones, rápido de crecimiento, propiedades de la madera, color, L*A*B*, colorímetro.

SUMMARY: Effect of the mineral nutrients and characteristic of the ground and environmental conditions on heartwood color, wood density and extractive content in young *Tectona grandis* trees in Costa Rica (TEAK-COLOR).

Wood colour is an essential quality-related property of lumber and wood products and determines the value and the significance of a piece of wood in the woodworking industry. On the other hand, *Tectona grandis* had been planted as raw material for solid products in large areas in Costa Rica. However, wood from young *Tectona grandis* trees had demonstrated low quality and lower natural resistance because its heartwood differs in extractive quality from wood of naturally-grown trees in Myanmar. According to this problem, the objective of our research project is to establish and to examine the mineral nutrients and physical characteristic of the ground and environmental conditions effect on heartwood color in fast-growing plantations in Costa Rica.

The main results obtained are:

- The most important conclusion of the present study is that the soil characteristics (physical and chemical) have little influence on teak wood properties. Certain soil characteristics, such as the content of Calcium, Cupper, and Phosphorus, as well as the Sand and Lime percentages, may be variables of interest for further studies as they showed slight but interesting correlations with wood color in the present study.
- As well, the results showed that wood color is affected by others parameters of plantation, as age and height of tree and growth rate.
- The plantation characteristics affect mainly a^* and L^* and its change affect decay resistance.

In the others hand the genetic aspects was influence in wood color. It was found that wood color was controlled genetically and high hereditability values was found

Keywords: *Tectona grandis*, fast-growth plantation, wood properties, colour, L^* a^* b^* , colorimetry.

3. FUNDAMENTOS DEL PROYECTO O ANTECEDENTES

3.1. Objetivo General:

- ✚ Determinar si los factores relacionados a la composición química y características físicas del suelo (tipo de suelo), aspectos ambientales (temperatura y precipitación) o genéticos influyen en el color de la madera de albura y duramen proveniente de plantaciones de rápido crecimiento en Costa Rica. De la misma manera, si existe relación del color con la densidad de la madera, contenido de extractivos y su durabilidad natural.

3.2. Objetivos específicos

- a) Evaluar las características físicas del suelo (textura, densidad aparente, disponibilidad de agua, porosidad y resistencia del suelo) y composición química (pH, M.O, cantidad de fósforo, calcio, magnesio, aluminio y H+Al).
- b) Determinar la variación radial del color y el porcentaje de la madera en duramen para diferentes edades de árboles en Costa Rica.
- c) Establecer el nivel o grado de relación que pudieran presentar el contenido de extractivos y densidad con el color de la madera en duramen de teca.
- d) Establecer mediante ensayos acelerados de laboratorio, el posible nivel o grado de relación que pudiera existir entre el color de la madera de teca y su durabilidad natural. Así como su relación con la fertilidad del sitio.
- e) Establecer una posible relación con el color de la madera (descomposición en CIEL*a*b y la reflectancia) con las características físicas y químicas del suelo.
- f) Establecer una posible relación con el color de la madera (descomposición en CIEL*a*b y la reflectancia) con el nivel promedio de precipitación y balance hídrico del sitio donde se crece los árboles.
- g) Establecer en un ensayo de progenie el grado de heredabilidad del color de la madera en el duramen.

4. BREVE DESCRIPCION DE LA METODOLOGÍA

En el proyecto de investigación fue dividido en dos partes (ensayos), un primer gran muestreo fue realizado para cumplir con los objetivos específicos desde el “a” hasta el subjetivo “b”. Para cubrir el primer grupo de objetivos fueron seleccionadas 23 plantaciones con edad entre los 7-15 años en la parte norte (Zona norte) y noroeste (Pacífico norte) de Costa Rica. Dos condiciones de clima están presentes en esas regiones: clima tropical seco y clima tropical húmedo y representan las áreas de mayor desarrollo para la reforestación comercial con teca. Para cumplir el objetivo específico “g” se realizó el estudio en dos plantaciones ubicadas en dos sitios diferentes de la zona Nor-Oeste de Costa Rica, uno ubicado en la Península de Nicoya (Sitio 1) y el otro próximo a la frontera con Nicaragua (Sitio 2). Estas plantaciones son parte de ensayos experimentales de la empresa MACORI S.A. El muestreo en cada una de las plantaciones y la forma como fue obtenida la madera de cada uno de los árboles volteados puede ser consultada en los anexos del presente informe.

Estudio de suelo: En las plantaciones muestreadas se seleccionó, en un lugar con las condiciones promedio y próximas a las parcelas permanentes de medición, se estableció una calicata de 1 x 1 x 1 m para su descripción y obtención de las muestras para el estudio físico y químico del suelo. Dentro de la calicata fueron determinados y medidos los diferentes horizontes, la cuales fueron variables en cada uno de ellos. En los 3 primeros horizontes fueron obtenidas muestras de suelo para el análisis de físicos y químicos. El detalle de cómo fueron realizados cada uno de los análisis pueden ser consultados en las publicaciones que son anexadas en el presente informe.

Propiedades de madera: para los objetivos que no contemplan el aspecto genético, fueron considerado otras propiedades de la madera, que son detalladas en la figura 1 y que indican como están las propiedades de la madera evaluadas.



Figura 1. Forma de obtener las muestras en la determinación de las propiedades físicas.

En el caso del estudio de estudio genético, el diseño de los bloques con los ensayos de plantación y el muestreo para las diferentes propiedades que se evaluaron en la madera son detallados en la figura 2. Al igual que en los anteriores ítemes los detalles de las propiedades evaluadas pueden ser consultadas en los anexos del presente documento.

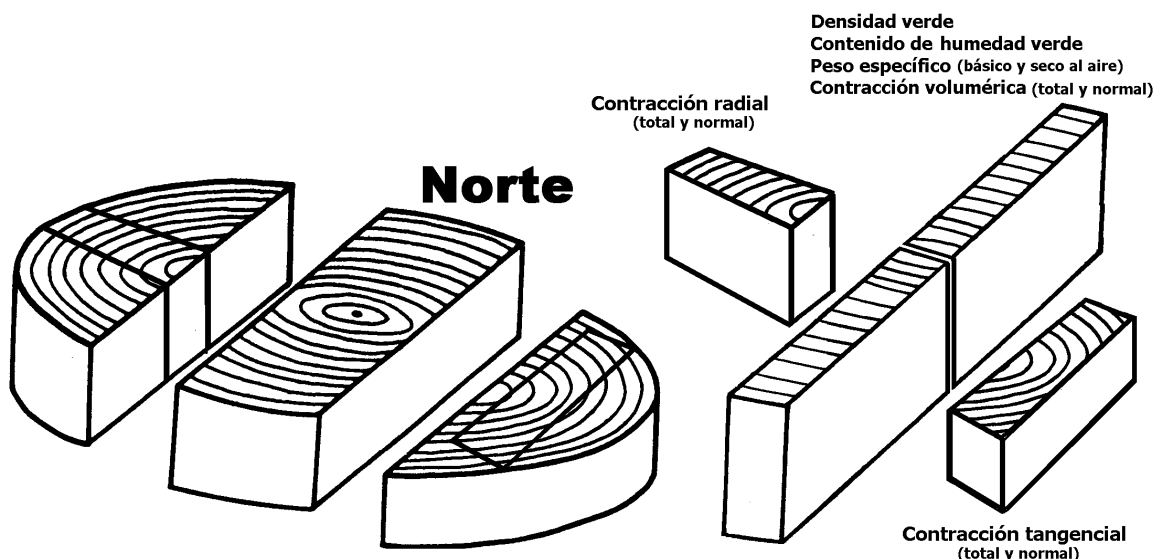

Figura 2. Diseño del bloque en el ensayo clonal y muestreo para la determinación de las propiedades de la madera.

Análisis estadístico: se aplicaron diferentes tipos de análisis apropiados según los diferentes objetivos planteados, dentro de los que destacaron, matrices de correlación, análisis de regresión lineal, análisis de varianza, entre otras.

5. PLAN DE ACCIÓN

Objetivos específicos	Cumplimiento	Producto	Observaciones
Evaluar las características físicas del suelo (textura, densidad aparente, disponibilidad de agua, porosidad y resistencia del suelo) y composición química (pH, M.O, cantidad de fósforo, calcio, magnesio, aluminio y H+Al).	100%	Base de datos de los 23 sitios evaluados. Información disponible para correlacionar con el color de la madera.	Esta información se utilizó para realizar las publicaciones 1 y 3 detalladas en la sección 8. El artículo preparado es mostrado en los anexos correspondientes.
Determinar la variación radial del color y el porcentaje de la madera en duramen para diferentes edades de árboles en Costa Rica.	100%	Curva que muestra la variación del color de la madera con la distancia de la medula, así como el diferente porcentaje de duramen con la edad.	La información recolectada de esta variación del color y la influencia de la edad del árbol sobre esta propiedad y el duramen son mostradas en los artículos 1, 2 y 3 mencionados en la sección 8 y los artículos preparados mostrados en los anexos correspondientes.
Establecer en un ensayo de progenie el grado de heredabilidad del color de la madera en el duramen.	100%	El color de la madera se puede controlar con las utilización de clones con los mejores colores de la madera	El detalle de este producto puede ser visto en las publicaciones 4 y 5 y en los anexos correspondientes.
Establecer el nivel o grado de relación que pudieran presentar el contenido de extractivos y densidad con el color de la madera en duramen de teca.	50%		Ver observaciones en la pagina siguiente
Establecer mediante ensayos acelerados de laboratorio, el posible nivel o grado de relación que pudiera existir entre el color de la madera de teca y su durabilidad natural.	100%	La madera con los colores más oscuros es la madera que presentan los mejores atributos para no sufrir la degradación de los agentes biológicos como los hongos.	La información puede ser consultada en la publicación 2 detallada en la sección 8 y su respectivo anexo.
Establecer una posible relación con el color de la madera (descomposición en CIEL*a*b y la reflectancia) con las características físicas y químicas del suelo.	100	El color se vio afectado por las propiedades físicas y químicas del suelo. También fue encontrado que otras propiedades fueron afectadas.	Los resultados pueden ser consultados en los artículos 1 y 3 del presente documento.
Establecer una posible relación con el color de la madera (descomposición en CIEL*a*b y la reflectancia) con el nivel promedio de precipitación y balance hídrico del sitio donde se crece los árboles.	100%	Tanto la fertilidad del suelo como las condiciones ambientales afectan el color de la madera. No obstante parece ser que el elemento más importante es las condiciones ambientales del sitio las que más determina el color de la madera el color del duramen de teca.	Nuevamente esto puede ser consultado en los artículos 1 y 3 de este trabajo.

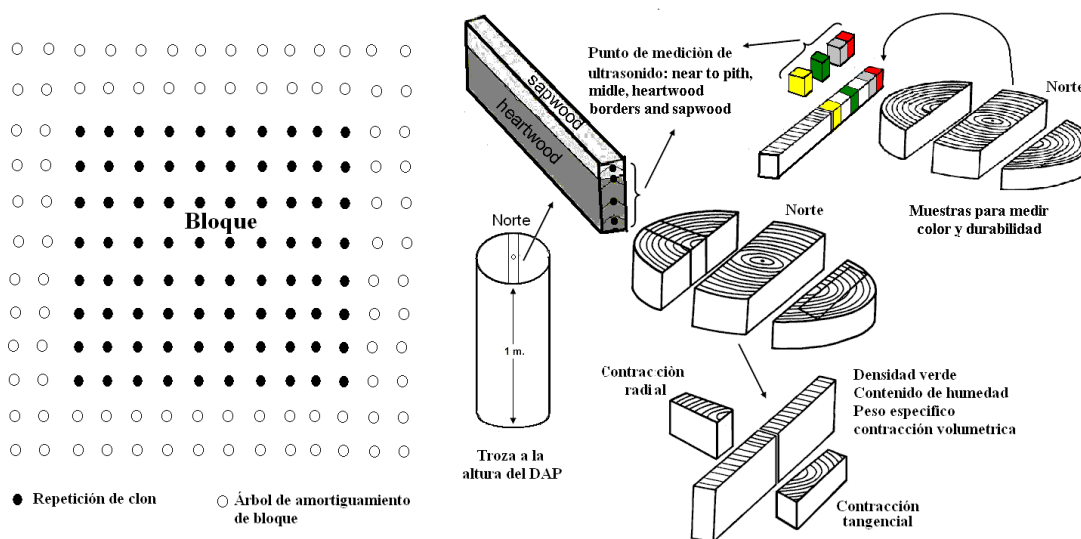
Observaciones en el objetivo específico “Establecer el nivel o grado de relación que pudieran presentar el contenido de extractivos y densidad con el color de la madera en duramen de teca” En este objetivo específico no se cumplió, debido a diferentes razones que son detalladas a continuación:

1. Para realizar el estudio de una sola muestra se necesita alrededor de 1 día de trabajo y se tenían en la totalidad alrededor de 250 muestras, por lo que el tiempo que iba a involucrar era muy extenso
2. Este ensayo demanda muchos reactivos químicos, por lo que el costo es alto
3. Se encontró en la literatura que dicho trabajo ya ha sido publicado ampliamente.

6. PRINCIPALES RESULTADOS Y/O CONCLUSIONES OBTENIDOS

Dentro de los principales resultados obtenidos del presente proyecto de investigación pueden ser señaladas los siguientes aspectos:

- Los aspectos físicos y químicos del suelo en general no presentan grandes efectos en las propiedades del color de la madera, ya que parece que el color esta relacionado más con las condiciones climatológicas del sitio. Aunque algunas características pueden estar influenciando en el color, como el contenido de calcio, cobre y fósforo por la parte química y de los aspectos de las características físicas del suelo están el porcentaje de arena y lino, estos tienen una relación directa con las condiciones climáticas.
- Así mismo, fue encontrado que además de que las propiedades físicas y químicas del suelo o como hemos llamado efecto indirecto de las condiciones ambientales sobre el color de la madera, que otros aspectos tales como edad del árbol, tasa de crecimiento y densidad de plantación, dichos parámetros regulados por el manejo de las plantaciones, afectan el color de la madera
- En lo referente al aspecto genético, se encontró que los parámetros del color de la madera pueden ser controlados genéticamente y lo más importante de esto es que poseen un alto índice de heredabilidad, lo cual sin duda permitirá seleccionar clones con mejores características de color.

7. GESTIÓN DEL PROYECTO E INCONVENIENTES

Al iniciar el proyecto que no se contaba con el calorímetro, por lo que las mediciones de color se atrasaron en un año, no obstante una vez que se obtuvo el equipo, las mediciones fueron bastante rápidas y se logró terminar las mediciones según lo programado en el proyecto.

Este proyecto involucró un número considerable de giras, con el fin de recolectar el material para realizar los ensayos. Como suele suceder los efectos climáticos fueron los principales problemas para realizar esta actividad. Así mismo, esta actividad es preferible realizarla en los meses de verano, que se extiende desde enero a mayo, sin embargo por el sistema presupuestario del ITCR que inicia la ejecución de los proyecto a mitad o finales de mayo, se contó con poco tiempo para realizar las actividades de aprovechamiento.

La actividad involucró que durante el desarrollo del proyecto el cambio e incorporación de investigadores, dando como resultado que algunas actividades se demoraran más de lo debido. Sin embargo, esto no involucró atrasos para la finalización del proyecto.

8. APORTE DE INFRAESTRUCTURA: DOCENCIA DEL CENTRO O LA ESCUELA

1. **Un colorímetro:** dado por el proyecto de la VIE para equipar los diferentes laboratorios.
2. **Mantenimiento y reparación del vehículo** FORD placa # 265-107, utilizado durante el desarrollo del proyecto y combustible para otros vehículos. También reparación del tractor/cargador FORD 6610 del CIIBI.

9. DIVULGACIÓN DE RESULTADOS

Fueron generados diferentes artículos científicos para sean publicados en revistas indexadas y una de ellas en la revista de la escuela de nuestra universidad:

1. MOYA, R. PEREZ, D., 2008. Effect of physical and chemical soil properties on physical wood characteristics of *Tectona grandis* plantations in Costa Rica. Journal of Tropical Forest Science 20(4): 147–155. (Artículo ya publicado en **Revista Indexada**)
2. MOYA, R. BERROCAL, A., 2008. Wood color variation in sapwood and heartwood of *Tectona grandis* and its relationship with plantation characteristics, site and decay resistance. Annals Forest Science (sometido en revista indexada enero de 2009)

3. MOYA; R., 2009. Variation of wood color parameters of *Tectona grandis* and its relationship with physical environmental factors in Costa Rica. Forest ecology and management (a someter esta revista indexada en los próximos dos meses)
4. MOYA; R. MARIN, D., MURILLO, O., LEANDRO, L. 2009. Genetic study of several physical properties, wood color, decay resistance and stiffness of *Tectona grandis* clones. Silve genetica (a someter esta revista indexada en los próximos dos meses)
5. MARIN, D., MOYA, R. Application of ultrasound and Ciel L*a*b* color systems in genetic selection of fast growth *Tectona grandis* (L.f) clones. Kuru: Revista Forestal (a someter en los próximos dos meses)

9.1. Divulgación externa internacional

1. Ponencia en Costa Rica: "Relation of wood color determined by Ciel L*a*b* color systems and its durability in wood of *Tectona grandis* form fast growth plantation in Costa Rica". II Taller Latinoamericano de Ensayos no destructivos en productos de madera. 2-4 de diciembre de 2008. San José – Costa Rica.
2. Ponencia en Costa Rica: "Application of ultrasound and Ciel L*a*b* color systems in genetic selection of fast growth *Tectona grandis* (L.f) clones". II Taller Latinoamericano de Ensayos no destructivos en productos de madera. 2-4 de diciembre de 2008. San José – Costa Rica.

9.2. Congresos internacionales

MOYA, R., BERROCAL, A., LEANDRO, L., 2008. Relation of wood color determined by Ciel L*a*b* color systems and its durability in wood of *Tectona grandis* form fast growth plantation in Costa Rica. En. Leandro, L. (ed). Libro de Resúmenes II Taller Latinoamericano de Ensayos no destructivos en productos de madera. 2-4 de diciembre de 2008. San José – Costa Rica. p.48.

MARIN, D., MOYA, R., 2008. Application of ultrasound and Ciel L*a*b* color systems in genetic selection of fast growth *Tectona grandis* (L.f) clones. En. Leandro, L. (ed). Libro de

Resúmenes II Taller Latinoamericano de Ensayos no destructivos en productos de madera.
2-4 de diciembre de 2008. San José – Costa Rica. p.51.

10. AGRADECIMIENTOS

Los investigadores de este proyecto dan las gracias a las siguientes personas, organizaciones y empresas: Ing. Rafael Córdoba, por sus aportes y comentarios acertados sobre el tema de secado de madera, Ph.D. Edwin Canessa, por sus aportes en el área de anatomía de la madera, Al Dr. Rafael Serrano, también por valiosa ayuda. A los funcionarios del Centro de Investigación en Integración Bosque Industria (CIIBI) por su trabajo en la ejecución de los ensayos, a la Unidad de transportes del ITCR, así como también a todas las personas que colaboraron en las plantaciones en labores de corta, extracción y troceo del material. A la Vicerrectoría de Investigación y Extensión del Instituto Tecnológico de Costa Rica, por el financiamiento del proyecto. A las empresas, Maderas Preciosas de Costa Rica (MACORI), Panamericam woods S.A. y al Grupo Ecodirecta por la donación de los árboles de teca utilizadas en este proyecto.

11. **ANEXOS** Se adjuntan todos los artículos científicos, notas técnicas, plegable informativo, poster y demás información pertinente.

1-Artículos científicos

1. MOYA, R. PEREZ, D., 2008. Effect of physical and chemical soil properties on physical wood characteristics of *Tectona grandis* plantations in Costa Rica. Journal of Tropical Forest Science 20(4): 147–155. (Artículo ya publicado en revista Indexada)

2. MOYA, R. BERROCAL, A., 2008. Wood color variation in sapwood and heartwood of *Tectona grandis* and its relationship with plantation characteristics, site and decay resistance. *Annals Forest Science* (sometido en revista indexada enero de 2009).

Wood colour variation in sapwood and heartwood of young trees of *Tectona grandis* and its relationship with plantation characteristics, site, and decay resistance

Short title: Wood colour variation in trees of *Tectona grandis*

Róger MOYA*

Instituto Tecnológico de Costa Rica, Escuela de Ingeniería Forestal, Apartado 159-7050, Cartago, Costa Rica. Email: rmoya@itcr.ac.cr

Alexander BERROCAL

Instituto Tecnológico de Costa Rica, Escuela de Ingeniería Forestal, Apartado 159-7050, Cartago, Costa Rica. Email: aberrocal@itcr.ac.cr

*Corresponding author

Wood colour variation in sapwood and heartwood of young trees of *Tectona grandis* and its relationship with plantation characteristics, site, and decay resistance

Summary

- Wood colour of *Tectona grandis* produced from fast-growth plantations is highly variable and the causes of this variation are relatively unknown.
- With the purpose of understanding the colour variation, different fast-growth plantations were sampled with different growth rates, tree ages, and sites. The wood colour was measured with a CIELab system.
- Results showed only a significant correlation between L* and a*. L* and a* were correlated with pith distance in heartwood, but not for b*. No correlations were found between L* and b* in sapwood colour and plantation characteristics, while a* was highly correlated with age and height of tree and growth rate. In heartwood, tree age and diameter at breast height (DBH) were correlated with all colour parameters, but tree height and plantation density were correlated with a* and b*. Cluster site had a strong correlation with only L*. Multiple correlation analysis showed that tree age and DBH are the main plantation characteristics that determine L* and a* in heartwood. The b* was not correlated with decay attack, a correlation was found with L* and a* for both sapwood and heartwood.
- The plantation characteristics affect mainly a* and L* and its change affect decay resistance.

Keywords: CIELab colour system / tropical wood / sapwood / hardwood / management plantation.

1. INTRODUCTION

Wood colour differs widely among species as well as within a single tree (Nishino et al., 1998; Liu et al., 2005). Wood colour is an important deciding feature for specific uses such as furniture and decorative veneers. Hence, colour appearance is considered an important attribute in the marketing phase (Mazet and Janin, 1990; Vetter et al., 1990). There are several colorimetric systems for measuring wood colour, and one of the most accurate and commonly used is CIELab colour systems, for colour variation (Sotela et al., 2008), wood colour related to plant genetic sources (Sotela et al., 2008), effect of drying on colour (Möttönen et al., 2002), effect wood colour on decay resistance (Gierlinger et al., 2004), and effect of thermal treatment on wood colour (Johansson and Morén, 2006).

Tectona grandis Linn F. has been widely planted in all tropical regions including Latin America, Asia, Africa, and Oceania, covering approximately 6 million hectares (FAO, 2006). Teak wood is well-known in the international market for its durability and unique esthetic properties (Tewari, 1999) and is a premier hardwood valued for its golden and brown colour (Thulasidas et al., 2006). According to Bhat (1999), there are four colour groups for *T. grandis* wood from native areas: (i) uniform golden yellow to brown colour (typical) (ii) a second that is darker in colour (iii) a third with a uniform grey-brown colour produced from trees that grow no larger than the pole stage, and (iv) a group that is lighter or more yellowish and of uniform colour. However, short-rotation trees growing in forest plantations generally fetch a lower price in the timber market because the wood is considered inferior in its quality attributes, such colour, density, and mechanical properties (Thulasidas et al., 2006).

In Costa Rica, large teak plantations have been established (Moya and Pérez, 2007) and have been managed for fast growth and high timber productivity (Bermejo et al., 2004; Perez and Kanninen, 2005), and therefore trees are felled in a short rotation period of less than 20 years. Another important point about teak wood from trees growing in forest plantations is that its colour is usually light brown with a large variation. This characteristic lowers the teak market price, and has led to the nickname of “baby teak wood” (Moya and Pérez, 2007).

Recent studies on teak report the causes of wood colour variation, mainly tree age, and its effects on decay resistance (Bhat et al., 2005; Thulasidas et al., 2006; Lukmandaru and Takahashi, 2008). However, wood colour is influenced by many factors including

site environmental factors, stand conditions and management, plant genetic source, and age (Phelps et al., 1983; Rink and Phelps, 1989; Saranpää, 2003). Also, those studies had been focused on the heartwood portions and few considerations were given to the sapwood. Several studies of fast-grown *T. grandis* trees have shown that a high heartwood fraction is present. Perez and Kanninen (2003) indicated that sapwood fractions can reach 45% of the total volume at 30 years, increasing in young plantation. Bhat (2000) mentioned that young trees have a high proportion of sapwood, meaning a reduction of natural durability.

With the purpose of understanding colour variation of fast-growing *T. grandis*, different trees were sampled, covering different growth rates, ages, and three cluster sites in Costa Rica. The objective was to explore the effect of plantation characteristics (growth rate, tree age, diameter at breast height, and tree height), site, and location of boards relative to the pith on colour in sapwood and heartwood measured by CIELab (L^* , a^* , b^*) colour systems. Also, the relationship of colour coordinates ($L^*a^*b^*$) and the effect of colour variation was determined for decay resistance.

2. MATERIALS AND METHODS

2.1. Study area and sample plantations

A total of 23 plantations of 7 to 15 years were selected in the north and northwest regions of Costa Rica covering three cluster sites (Fig. 1). Annual precipitation was between 1500 and 5000 mm, with an average annual temperature of 20-28°C. There was a long dry season between January and April in the northwest regions of clusters 2 and 3 and a short dry season in February and March in north regions of cluster 1 (Bolaños and Watson, 1993). The 23 sampled plantations were established by three different private companies along the study area. Stand density varied between 160 to 580 trees/ha, depending on plantation age, management, and site conditions. Plantation conditions were detailed previously in Table 1 in Moya and Pérez (2008).

2.2. Sampled trees and wood sample preparation

A total of 3 representative trees next to each plot were selected by considering mean diameter breast height, straightness of the stem, normal branching, and absence of pests or diseases. North orientation was marked on each tree prior harvesting. One log, 40-cm long, was cut at breast height for each tree. They were stored in plastic bags for further laboratory analysis. Each log was sawn into radial sections of 3-cm width through the pith in the north to south direction, (Fig. 2). These samples were

conditioned at 22°C and 60% relative humidity for several weeks until reaching a moisture content of 11-12%. Then all radial sections were re-sawn into 2.5 cm thick strips radially from center to bark. Each strip was labeled according to the radial position in the stem, indicating the relative distance from the pith. Also, each strip was labeled according to sapwood and heartwood. Tangential surfaces were sanded to minimize the risk of variation of colour and after 20 h the wood colour was measured.

Colour measurement

Wood colour was measured using a portable Miniscan XE plus colorimeter (HUNTER LAB) at ambient temperature and humidity. The colorimeter was calibrated each time it was used, using a white standard probe supplied by the company. The reflectance spectra were recorded according to the standardized CIELab chromaticity system as a function of wavelength (BYK-Gardner, 2004). The measurement was within the visible range of 400–700 nm at intervals of 10 nm with a measuring aperture of 11 mm. For reflection readings, the observer component was set at an angle of 90° to the normal surface of the specimen. The standard illuminant D65 (corresponding to daylight at 6500 K) was used as the colour space measuring and computing parameters. The CIELAB (L^* , a^* , b^* coordinates) colour system estimates the value of three variables: coordinate L^* for lightness, representing the position on the black–white axis ($L=0$ for black, $L=100$ for white); coordinate a^* defines the position on the red–green axis (positive values for red shades, negative values for green shades); and coordinate b^* the position on the yellow–blue axis (positive values for yellow shades, negative values for blue shades). Three measurements along the length were taken from each wood sample and average values were obtained for L^* , a^* and b^* coordinates.

2.4. Decay Resistance

Specimens (2.5 x 2.5 x 2.5 cm) were cut at the same location where wood colour was measured. The white-rot fungi, *Trametes versicolor* (L. Fr.) and *Pycnoporus sanguineus* (L.) Merrill, were used for testing natural decay resistance following ASTM D-2017-81 (ASTM, 2003). The relative resistance of each test block to decay was measured as the percentage loss in oven-dry weight during a 16-week exposure to the fungi. Although ASTM D-2017-81 specifies that sample dimensions are 2.5 x 2.5 x 0.9 cm, we modified the procedure to use 2.5 x 2.5 x 2.5 cm samples.

2.5. Statistical Analysis

The normality and the presence of extreme data or outliers were verified for each colour parameter. To establish the relationship within colour coordinates ($L^*a^*b^*$) in

sapwood and heartwood, and the effect of pith distance and decay resistance on colour variation, regression analysis was applied. Pearson matrix correlation was applied to show the relationship between colour coordinates and plantation characteristics (growth rate, age and height of tree, diameter at breast height) and site. Finally, we used forward stepwise analysis to define the plantation variables most affecting the wood colour. The colour coordinates of all boards in a tree were averaged and used to establish the Pearson matrix correlation with plantation characteristics. Statistical SAS (SAS Institute Inc.) and STATISTICA 6.0 (Statsoft Inc.) programs were used to evaluate the meaning of the regression model.

3. RESULTS AND DISCUSSION

3.1. Wood colour

The lightness index (L^*) ranged from 63.6 to 80.9 in sapwood and from 46.8 to 70.6 in heartwood. The redness index (a^*) ranged from 1.9 to 11.7 and 5.1 to 13.6 for sapwood and heartwood, respectively; and yellowness (b^*) from 19.4 to 32.6 for sapwood and from 4.1 to 29.5 in heartwood. From a chemical point of view, the variation of extractives or chemical compositions of lignin produced from different soil properties can explain the wood colour variation of heartwood (Burtin, 1998). For example, some works have show that redness (a^*) and lightness (L^*) are correlated with extractive contents, while yellow tones are primarily governed by the photochemistry of the major wood components, especially lignin.

Table 1 shows the average colorimetry results for sapwood and heartwood of *T. grandis* in CIELab colour systems. Note that the values in colour coordinates are positive. All objects can have their colour described by three variables using CIELab: L^* =lightness ranging from 0 to 100, 0 being total blackness and 100 pure white, a^* =green–red chroma coordinate ranging from -100 to 100, with negative values reflecting the dominance of greenness and positive ones redness, and b^* = blue-yellow chroma coordinate ranging from -100 to 100, with negative values reflecting the dominance of blueness and positive ones yellowness (Hunterlab, 1995). Therefore, colour composition of *T. grandis* wood can be described by combination colours of different tonalities of lightness, red, and yellow. We can also note that the values of L^* and b^* in sapwood and L^* , a^* , and b^* values of heartwood were narrowly distributed compared with the possible ranges, the variation coefficients being minor to 12.35% (Table 1). The a^* values had the largest distribution compared with the possible range in sapwood, with a coefficient variation of 33.28% (Table 1). On the other hand, the colour

composition of heartwood and sapwood are different, as expected. Heartwood colour has higher values of L^* and lower values of a^* in relation to sapwood (Table 1). The change in colour between sapwood and heartwood is presumed to be from oxidation and polymerization of phenolic components in heartwood by chemical or enzymatic processes (Burtin et al., 1998; Gierlinger et al., 2004).

Although lower variation was found in coordinates of the CIELab colour system for *T. grandis*, with the exception of a^* coordinates in sapwood, the wood colour variation is considered large for end users (Bhat, 1999). We can explain it because the variation of colour space (three-dimensional model) is the quadratic summation of differences in each coordinate (Gonnet, 1993). Mazet and Janin (1990), in researching 90 French and Italian assessors drawn from woodworking industries with oak-veneer samples, reported that a difference of over 2 units in $[(L^*-L^*)^2 + (a^*-a^*)^2 + (b^*-b^*)^2]$ are distinguishable to the human eye. For agricultural or horticultural applications this difference varied from 1.0 to 3.0 (Voss and Hale, 1998). Therefore, a difference in 2 points in different samples of *T. grandis* in all coordinates of colour systems will produce a difference to the human eye.

The L^* , a^* , and b^* values obtained in wood from fast-growth plantation of *T. grandis* in Costa Rica are not comparable with other studies. For example, Thulasidas et al. (2006) reported average values of 56.34, 6.85, and 23.44 in L^* , a^* , and b^* coordinates, respectively, for wood from trees growing in plantations in India. The Costa Rican teak wood has more lightness and less redness than Indian wood, because it was found that in the Costa Rican wood, the L^* values (lightness coordinate) are greater and a^* values (redness coordinates) lower than in Indian wood. However, these results must be carefully considered since different colour equipment was used in each study. We used a colorimeter and Bhat et al. (1999) used a UV spectrophotometer, and we can assume differences in wood colour determination between equipment (Vetter et al., 1990). On the other hand, Lukmandaru and Takahashi (2008), with trees from different ages on Java Island, found index ranges wider than ours. They measured ranges from 75 to 77 and 54 to 60, for sapwood and heartwood, respectively in L^* , for a^* coordinates from 2 to 3 in sapwood and 4 to 6 in heartwood, and b^* coordinates ranged from 22 to 25 in sapwood and 24 to 26 in heartwood. All these values are greater than values reported in the Table 1.

3.2. Relation between wood colour coordinates

Figure 3 shows the relationship between the colour parameters, separating the heartwood and sapwood measurements. A correlation was found only between L^* and a^* in sapwood and heartwood. A lower coefficient of determination was found in both, $R^2=0.38$ for heartwood and $R^2=0.43$ for sapwood (Fig. 3a). No significant correlation was found between L^* and b^* (Fig. 3b) and b^* and a^* (Fig. 3c). These results show that the variation in wood colour of *T. grandis* is produced by an inverse variation between L^* and a^* coordinates, black and redness, respectively. Nishino et al. (1998) measured the correlation between different colour parameters of many tropical species from Guiana and these results agree with the *T. grandis* findings. They found significant relationships between L^* and a^* ; and not a statistically significant relation between a^* and b^* . However, relationships between a^* and b^* in Guiana wood conflicted with our results. For another hardwood, *Fagus sylvatica*, from a temperate climate, was found that the parameters of CIEL*a*b* colour systems were correlated (Liu et al., 2005), L^* with a^* , L^* with b^* , and a^* with b^* . Results differed with *T. grandis* in that an L^* a^* correlation was found.

3.3. Wood colour variation with distance from the pith

The colour coordinates L^* and a^* were statistically ($\alpha=0.05$) correlated with pith distance for heartwood; and no correlation was found in sapwood for any colour parameters and pith distance (Fig. 4). However, low correlation coefficients were found in heartwood, $R= -0.36$ (or $R^2= 0.12$) for the relationship of L^* with pith distance (Fig. 4a) and $R= 0.36$ (or $R^2= 0.12$) for the relationship of a^* with pith distance (Fig. 4b). For coordinate b^* , no significant correlation was found (Fig. 4c). According to these results, the heartwood colour is lightest with the lowest redness near the pith, and for variation with pith distance, the wood is darker and redness increases. Kokutse et al. (2006) and Bhat et al. (2005) with teak trees grown in Togo and India, respectively, in fast-growth plantations agreed with the wood colour variation found for teak trees growing in Costa Rican plantations, in colour variation with pith distance for L^* and a^* parameters for CIELAB colour systems, and no significant difference in b^* colour parameters.

3.4. Wood colour variation with plantation characteristic

No correlations were found between L^* and b^* parameters of sapwood colour and plantation characteristics, while the a^* coordinate was highly correlated ($P<0.01$) with tree age and growth. Low correlation ($P<0.05$) was found between a^* coordinate and tree height and plantation density (Table 2). Redness index (a^*) increments with age and height of the tree. Also, a decreasing growth rate and plantation density increment

redness value. In heartwood, tree age and DBH were highly correlated with all colour parameters, except the b^* coordinate with tree age which had a low correlation. There was a negative correlation between lightness index (L^*) and tree age and DBH, and a positive correlation was determined among the redness and yellowness indices, and tree age and DBH (Table 2). The a^* and b^* coordinates were not statistically correlated with tree height and plantation density, but the L^* coordinate was negatively and positively correlated, respectively (Table 2). Growth rate correlated positively and negatively to L^* and a^* coordinates, respectively, but no correlation was found with b^* coordinates. The cluster sites were independent variables with less effect in wood colour coordinates. There was a strong correlation between this variable and yellowness index (Table 2). The Thulasidas et al. (2006) study agreed with our results. They measured the heartwood colour variation of home garden *T. grandis* trees from wet and dry localities of Kerala (India) and found that only the yellowness index (b^*) was different between dry and wet localities and no significant difference was observed among localities with regards to redness (a^*) and lightness (L^*) indices. These results probably indicated that the yellow coordinates of *T. grandis* colour are more affected by different soils or different fertility of soils; however it is necessary to confirm this.

All plantation characteristics significantly affected colour parameters, and it was determined that there are strong relationships among all characteristics. No correlation was found between cluster sites and plantation characteristics. Tree age and plantation density were the most correlated variables (Table 3). This means that wood colour is produced by a combination of the plantation characteristics. Multiple correlation analysis showed that relationships between wood colour parameters and plantation characteristics were roughly explained by the different model parameters, and that tree age was the main plantation characteristic that determines redness and lightness index of wood colour of *T. grandis*, but cluster sites affected mainly the yellowness index (b^*) of heartwood. DBH affected the coordinates of wood colour in heartwood, having the greatest effect in lightness index (10.1%). Growth rate affected only a^* coordinates in heartwood (Table 4).

Sapwood was less affected than heartwood by plantation characteristics; only a^* coordinate (redness index) was affected for several parameters of plantations (Table 2), but some tree variables were highly significant (Table 3). It was mentioned above that the colour composition of heartwood and sapwood are different, which is presumed to be from composition and abundance of extractives in heartwood (Burtin *et*

al., 1998; Gierlinger *et al.*, 2004) that depend the several factors, such tree age, soil composition, part of tree. Extractives are not deposited in sapwood tissue (Hillis, 1987).

Tree age, DBH, and growth rate have shown significant correlation with colour parameters for various others species, similar to the *T. grandis* results. For example, Gardner and Barton (1960) found that redness increased with age of the heartwood. Gierlinger *et al* (2004) studying hydrides of Japanese larch have shown that old trees have significant redder hue (a^*) than young trees. Also, they determined that slowly grown mature trees from native sites had higher a^* and b^* values, compared with young rapidly grown plantation trees. Klumpers *et al.* (1993) found that the heartwood became increasingly redder (a^* coordinate) with the age of *Quercus robur*. On the other hand, the growth rate was negatively correlated for yellow hue (a^*), but not with L^* or b^* in *Calycophyllum spruceanum* growing the Peruvian Amazon (Sotela *et al.*, 2008). Wilkins and Stamp (1990) reported that faster growing trees of *Eucalyptus grandis* produced redder heartwood (increasing a^* coordinate). Rink (1987) found that faster growing trees of *Juglans nigra* produced lighter coloured heartwood.

The low correlation coefficients found between wood colour coordinates and plantation characteristics in heartwood suggests that for the wood colour in *T. grandis*, other factors may have a larger influence, such as genetics or different environmental or soil conditions. For example, Nelson *et al.* (1969) found that soil properties are associated with wood colour of *Juglans nigra* and they are independent of effects of growth rate and tree age. Recently, Phelps *et al.* (1983) and Gierlinger *et al.* (2004) observed that in *Juglans nigra* and several Larix species, greater differences were found in colour coordinates between the sites. These results agreed only with b^* coordinates of *T. grandis*. Additionally, the wood colour can be influenced by genetic factors and it was not considered in these studies. There are few studies on genetic effects on wood colour in tropical species. Sotela *et al.* (2008) for *Calycophyllum spruceanum*, for example, reported that wood colour had relatively low heritability for L^* colour parameter and no significant correlation was determined for a^* and b^* coordinates.

3.5. Decay resistance relative to colour

The values of weight loss from exposure to *Trametes versicolor* and *Pycnoporus sanguineus* are plotted for the coordinates of L^* and a^* in Figure 4. The b^* coordinates were not plotted because no correlation was determined with weight loss (Table 5). Note that a positive correlation existed between weight loss and L^* and a^* coordinates for both white rot fungi (Fig. 5a and 5b). As L^* and a^* coordinates were negatively

correlated (Fig. 3a), there is a negative correlation between weight loss and a^* coordinates (Fig. 5c and 5d), however, Pearson coefficients were not significant in sapwood tissue (Table 5). Another important point is that the greatest values of correlation coefficient occurred when all samples were considered ($r > 0.62$) and lower values were found for sapwood and heartwood separately (Table 5).

Several studies on the correlation between colour and durability have been investigated for heartwood (Bhat *et al.*, 2005; Kosutse *et al.*, 2006; Lukmandaru and Takahashi, 2008), although they did not include the effect of sapwood colour on decay resistance. The increasing of L^* coordinates values of heartwood, in our results for sapwood and heartwood (Fig. 5a), were also demonstrated by Bhat *et al.* (2005) and Kosutse *et al.* (2006) with several brown- and white-rot fungi, and with termites (Lukmandaru and Takahashi, 2008). However, conflicting results have been found for a^* and b^* coordinates. The b^* coordinate was not correlated with *P. sanguineus* attack resistance (Table 5), whereas Kosutse *et al.* (2006) found significant effects for same fungus. However, the significance of a^* and b^* colour parameters could depend on the species of fungi, and for this reason we agree with Kosutse *et al.* (2006) that “the colour parameters for redness and yellowness were not good indicators of durability in teak wood”.

There is a hypothesis that the relationship between colour and decay resistance is indirect, based on the influence of extractives on both (Gierlinger *et al.*, 2004). However, this can be applied to heartwood, but not sapwood. Many studies have demonstrated that extractives such as tectoniquinone; naphthoquinone; and extractives soluble in petroleum-ether, methanol, acetone/water, and ethanol/water affect decay resistance in heartwood, and they vary from pith to bark (Lukmandaru and Takahashi, 2008; Hupt *et al.*, 2003; Rudman and Da Costa, 1959; Thulasidas and Bhat, 2007). Sapwood decay resistance is more complex, where we found that L^* and a^* was correlated with *T. versicolor* attack and a^* was correlated only with *P. sanguineus* (Table 5, Fig. 5). However, no correlations were determined between coordinates of wood colour and distance from the pith (Fig. 4). Histochemical studies on compositions of sapwood and heartwood and their transition has been carried for *T. grandis*. It was shown that different peroxidases, adenosine triphosphatase, extractives, and chemical components varied within sapwood and sapwood/heartwood transition (Datta and Kumar, 1987). Different chemical compositions across sapwood could be affecting decay resistance in *T. grandis*. On the other hand, Rudman and Da Costa (1959) established, based on extracted samples, which decay resistance is due to a gradual

change either in cell composition or structure as the tree ages. However, we have demonstrated in a recent study in young trees from fast-growth plantations (Moya et al., 2009) that large changes of dimensions occur with age for vessels, radial and axial parenchyma, and fibers.

4. CONCLUSION

Wood colour variation is present from pith to bark and it is a lineal combination of L* and a* coordinates in sapwood and heartwood of *T. grandis*. Also, the variation of L* and a* produced different decay resistance. Wood with higher values of L* and lower values of a* was less resistant to decay than wood with lower values of L* and higher values of a*. On the other hand, plantation characteristics affect mainly a* and L*. Although age and height of trees, growth rate, DBH, and plantation density significantly affects these coordinates, tree age is the main factor in plantations. However, b* coordinates were influenced by different plantation sites. Therefore, the wood colour variation in *T. grandis* is controlled by aging of trees, and through some methods of plantation management, we can control the L* and a* coordinates, which produce changes in wood colour. Also, the plantation site can control the L* parameters, with less influence in wood colour variation.

Acknowledgements

The authors wish to thank The Research Vice-Rector of the Technological Institute of Costa Rica (ITCR), and Precious Woods of Central America (MACORI), Ecodirecta Groups and Panamericans Woods for financial support in soil analyses. And Frank Beall for his comments and recommendations in this article.

REFERENCES

- ASTM-American Society for Testing and Materials, 2003. Standard method of accelerated laboratory test of natural decay resistance of woods. (ASTM D 2017-81 Reapproved 1994). Annual Book of ASTM Standards, Vol. 04.10., Philadelphia. USA. pp. 445-457.
- Bhat K.M., 1999. Is fast grown teak inferior in wood quality –An appraisal of wood figure (colour, grain, texture) from plantations of high input management. Wood News 9 (4): 48-49.
- Bhat K.M., 2000. Timber quality of teak from managed tropical plantations with special reference to Indian plantations. Bois et For. des trop. 263: 5-15.

- Khat K.M., Thulasidas P.K. and Florence E.J., 2005. Wood durability of home-garden teak against brown-rot and white-rot fungi. *Tree* 9: 654-660.
- Bermejo I., Cañellas I. and San Miguel A. 2004. Growth and yield models for teak plantations in Costa Rica. *Forest Ecol. Manag.* 189: 97-110.
- Bolaños R. and Watson V., 1993. Mapa ecológico de Costa Rica. Según el sistema de clasificación de zonas de vida del mundo de L. R. Holdridge. Escala 1: 200.000. Centro Científico Tropical, San José, Costa Rica.
- Burtin P., Jay-Allemand C., Charpentier J. and Janin G., 1998. Natural wood colouring process in *Juglans* sp. (*J. regia* and hybrid *J. nigra* 23 x *J. regia*) depends on native phenolic compounds accumulated in the transition zone between sapwood and heartwood. *Trees* 12: 258-264.
- BYK-Gardner L., 2004. CIE L*a*b* system. Color-guide 45/0 operating instructions, MD, USA, pp. 1-67.
- Data S.K. and Kumar A., 1987. Histochemical studies of the transition from sapwood and heartwood in *Tectona grandis*. *IAWA Bull.* n.s. 8(4): 363-368.
- FAO, 2006. Global planted forest thematic study: results and analysis, by Del Lungo J.B. and Carle J., 2006. *Planted Forests and trees: Working paper 38*. Rome.
- Gierlinger N., Jacques D., Gradner M., Wimmer R., Schwanninger M., Rozenberg P. and Pâques L.E., 2004. Colour of larch heartwood and relationships to extractives and brown-rot decay resistance. *Trees* 18: 102-108.
- Gonnet J.F., 1993. CIELab measurement, a precise communication in power colour: an example with carnation (*Dianthus caryophyllus*) cultivars. *J. Hort. Sci.* 68: 499–510.
- Hillis W.J., 1987. *Heartwood and Tree Exudates*. Springer Verlag, New York. 272 p.
- Hupt M., Leithoff H., Meiser D., Richter H.G. and Faix O., 2003. Heartwood extractives and natural durability of plantation-grown teakwood (*Tectona grandis* L.) – a case study. *Holz Roh. Werkst.* 61: 473-474.
- Hunterlab, 1995. Use measurement of appearance. A Welly-Interscience publication, Welly and Sond, New York. p.345.
- Johansson D. and Morén T., 2006. The potential of colour measurement for strength prediction on thermally treated wood. *Holz Roh Werst.* 64: 104-110.
- Klumpers J., Janin G., Berker M. and Lévy G., 1993. The Influences of age, extractive content and soil water on wood color in oak: the possible genetic determination of wood color. *Ann. For. Sci.* 50 (Suppl.1): 403s-409s
- Kokutse A.D., Stokes A., Baillères H., Kokou K. and Baudasse C., 2006. Decay resistance of Togolese teak (*Tectona grandis*) heartwood and relationship with colour. *Trees* 20: 219-223.

- Liu S., Loup C., Gril J., Dumonceaud O., Thibaut A. and Thibaut B., 2005. Studies on European beech (*Fagus sylvatica* L.). Part 1: Variations of wood color parameters. *Ann. For. Sci.* 62: 625-632.
- Möttönen V., Alvila L. and Pakkanen T.T., 2002. CIEL*a*b* measurements to determine the role of felling season, log storage and kiln drying on coloration of silver birch wood. *Sand. J. For. Res.* 17: 179-191.
- Mazet J.F. and Janin G., 1990. La qualité de l'aspect des placages de Chênes (*Quercus petraea* and *Quercus robur*): mesures de couleur et critères de d'appréciation des professionnels français et italiens. *Ann. For. Sci.* 47(3): 255-268.
- Moya R., Berrocal A., Serrano R. and Tomazello M., 2009. Radial variation of anatomical features, wood density and decay resistance in teak (*Tectona grandis*) from two qualities of growing sites and two climatic regions of Costa Rica. *Invest. Agrar.: Sist. Recur. For.* 19 (in press).
- Moya R. and Pérez D., 2007. Processing and marketing of teakwood products from fast-grown teak plantations in Costa Rica. In Nair K., Bhat K.V., Anitha V., 2007. Abstracts Products and Marketing of teak wood products of planted forest. Regional Workshop Products and Marketing of teak wood products of planted forest. 25-28. September 2007. KFRI, Peechi, India. Pag. 24.
- Moya R. and Pérez D., 2008. Effect of physical and chemical soil properties on wood characteristics of *Tectona grandis* plantations in Costa Rica. *J. Trop. Forest Sci.* 20(4): 147–155.
- Nelson N.D., Maeglin R.R. and Wahlgren H.E., 1969. Relationship of Black Walnut Wood Color to Soil Properties and Site. *Wood Fiber* 1: 29-37.
- Nishino Y., Janin G., Chanson B., Détienne P., Gril J. and Thibaut B., 1998. Colorimetry of wood specimens from French Guiana. *J. Wood Sci.* 44:3-8.
- Nishino Y., Janin G., Yamada G. and Kitano D., 2000. Relations between the colorimetric values and densities of sapwood. *J. Wood Sci.* 46:267-272.
- Phelps J.E., McGinnes E.A., Garrett H.E. and Cox G.S., 1983. Growth-quality evaluation of black walnut wood. Part II—color analyses of veneer produced on different sites. *Wood Fiber Sci.* 15:177–185.
- Perez D. and Kanninen M., 2003. Heartwood, sapwood and bark content, and wood dry density of young and mature teal (*Tectona grandis*) tree grown in Costa Rica. *Silva Fennica* 37: 45-54.
- Perez D. and Kanninen M., 2005. Stand growth scenarios for *Tectona grandis* plantations in Costa Rica. *Forest Ecol. Manag.* 210: 425-441.
- Rink G., 1987. Heartwood color and quality variation in a young black walnut progeny test. *Wood Fiber Sci.* 19: 93-100.

- Rink G., Phelps J.E., 1989. Variation in heartwood and sapwood properties among 10-year-old black walnut trees. *Wood Fiber Sci* 21:177–182.
- Rudman P. and Da Costa W.B., 1959. Variation in extractive content and decay resistance in the heartwood of *Tectona grandis* L.f. *J. Inst. Wood Sci.* 3: 33-42
- Saranpää P., 2003. Wood density and growth. in Barnett J.R. and Jeronimidis G. (eds) *Wood quality and its biological basis*. Blackwell Publishing Ltd., Oxford, UK.
- Sotela C., Hernández R.E., Beaulieu J. and Weber J., 2008. Genetic variation in wood color and its correlations with tree growth and wood density of *Calycophyllum spruceanum* at an early age in the Peruvian Amazon. *New forest* 35: 57-73.
- Tewari D.N., 1999. A monograph on teak (*Tectona grandis*). International Book Distrutors. Dehra Dun. India. p. 345.
- Thulasidas P.K., Bhat K.M. and Okuma T., 2006. Heartwood colour variation in home garden teak (*Tectona grandis*) from wet and dry localities of Kerala, India. *J. Trop. Forest Sci.* 18: 51-54.
- Thulasidas P.K. and Bhat K.M., 2006. Chemical extractive compounds determining the brown-rot decay resistance of teak wood. *Holz Roh. Werkst.* 65: 121-124.
- Voss D.H. and Hale W.N., 1998. A comparison of the three editions of the Royal Horticultural Society Colour Chart. *HortScience* 33: 13–17.
- Vetter R.E., Coradin V.R., Martino E.C. and Camargos J., 1990. Wood colour – A comparison between methods. *IAWA Bull* 11: 429-124.
- Wilkins P. and Stamp C.M., 1990. Relationship between wood colour, silvicultural treatment and rate of growth in *Eucalyptus grandis* Hill (Maiden). *Wood Sci. Tech.* 24(4): 297-304.

Table 1. Colour parameters of *Tectona grandis* growing in Costa Rica with CIELab system.

Wood	L* (lightness)	a* (redness)	b* (yellowness)
Sapwood	73.8 (63.62 – 80.90)	5.8 (1.66 - 11.65)	25.22 (19.44 - 32.62)
Heartwood	58.15 (46.78 - 76.56)	10.4 (7.07 - 13.56)	25.91 (20.06 - 30.11)

Note: the values in parenthesis represent standard deviations and variation coefficients.

Table 2. Pearson correlation coefficients for the relationship between colour parameters in sampled plantation characteristics of *Tectona grandis* in Costa Rica.

Plantation characteristics	CIELab parameters in sapwood			CIELab parameters in heartwood		
	L*	a*	b*	L*	a*	b*
Tree age	-0.13 ^{ns}	0.38 ^{**}	0.09 ^{ns}	-0.55 ^{**}	0.42 ^{**}	0.26 [*]
Tree height	-0.09 ^{ns}	0.31 [*]	-0.08 ^{ns}	-0.28 [*]	0.20 ^{ns}	0.31 ^{ns}
DBH	-0.00 ^{ns}	0.14 ^{ns}	-0.04 ^{ns}	-0.40 ^{**}	0.38 ^{**}	0.38 ^{**}
Growth rate	0.15 ^{ns}	-0.38 ^{**}	-0.16 ^{ns}	0.41 ^{**}	-0.30 [*]	-0.06 ^{ns}
Density plantation	0.05 ^{ns}	-0.33 [*]	-0.09 ^{ns}	0.30 [*]	-0.22 ^{ns}	0.20 ^{ns}
Cluster	-0.23 ^{ns}	0.18 ^{ns}	-0.15 ^{ns}	-0.09 ^{ns}	0.16 ^{ns}	0.84 ^{**}

Legend: ** Statistically significant at 99% confidence level; * statistically significant at 95% confidence level, ns: not significantly different, DBH: diameter at breast height.

Table 3. Pearson correlation coefficients for the relationship among sampled plantation characteristics of *Tectona grandis* in Costa Rica.

Plantation characteristics	Tree age	Tree height	DBH	Growth rate	Density plantation	Cluster
Tree age	1					
Tree height	0.67 ^{**}	1				
DBH	0.56 [*]	0.85 ^{**}	1			
Growth rate	-0.80 ^{**}	-0.18 ^{ns}	0.02 ^{ns}	1		
Density plantation	-0.66 ^{**}	-0.55 [*]	-0.45 [*]	0.45 [*]	1	
Cluster	0.18 ^{ns}	0.25 ^{ns}	0.32 ^{ns}	-0.02 ^{ns}	0.24 ^{ns}	1

Legend: ** Statistically significant at 99% confidence level; * statistically significant at 95% confidence level, ns: not significantly different.

Table 4. Multiple correlation analysis for the relationship between wood colour parameters and plantation characteristics of *Tectona grandis* plantations in Costa Rica.

Wood properties	Correlation parameters		
	1 st	2 nd	3 rd
Redness index (a*) r = 0.387 ¹	Tree age ^{**} 0.15	-	-
Lightness index (L*) r = 0.649	Tree age ^{**} 0.304 ²	DBH ^{**} 0.101	-
Redness index (a*) r = 0.547	Tree age ^{**} 0.176	Growth rate ^{**} 0.093	DBH ^{**} 0.030
Yellowness index (b*) r = 0.844	Cluster ^{**} 0.698	DBH ^{**} 0.014	-

Legend: ** Statistically significant at 99% confidence level; * statistically significant at 95% confidence level. ¹Multiple correlation coefficient; ²Contribution of the parameter to the coefficient of determination (r²).

Table 5. Pearson correlation coefficients for the relationship between colour parameters and decay resistance of *Tectona grandis* in Costa Rica.

Type of wood	Colour coordinates	<i>Trametes versicolor</i>	<i>Pycnoporus sanguineus</i>
All samples: sapwood and heartwood (N=394)	L*	0.66**	0.64**
	a*	-0.65**	-0.62**
	b*	0.10 ns	0.07 ns
Sapwood tissue (N=127)	L*	0.43*	0.16 ns
	a*	-0.62**	-0.32*
	b*	0.19 ns	0.08 ns
Heartwood tissue (N=267)	L*	0.55**	0.47*
	a*	-0.44*	-0.33*
	b*	0.07 ns	0.07 ns

Legend: ** Statistically significant at 99% confidence level; * statistically significant at 95% confidence level, ns: not significantly different.

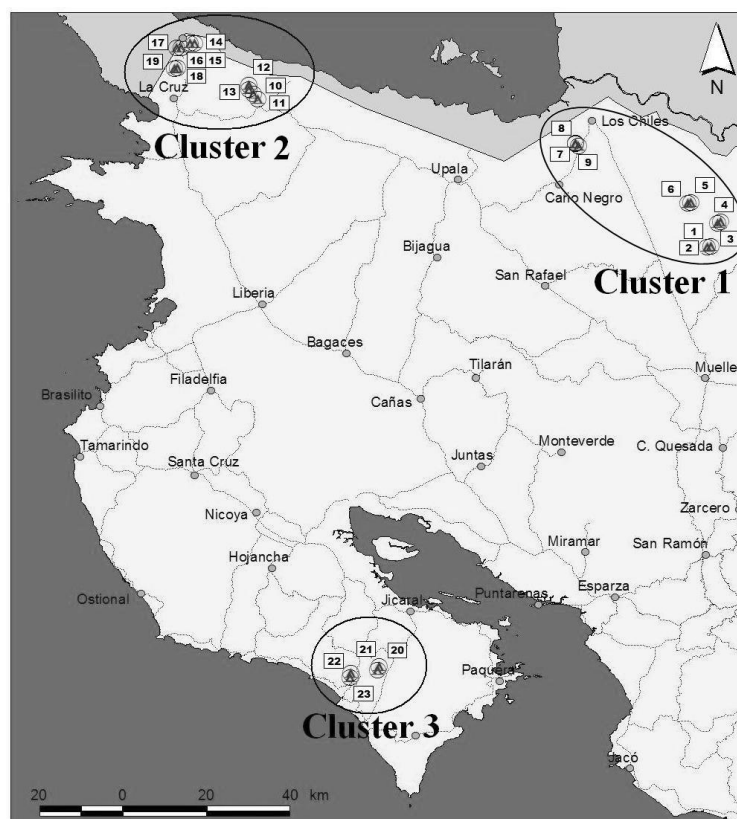

Figure 1. Locations of plantations sampled in the north and northwest regions of Costa Rica.

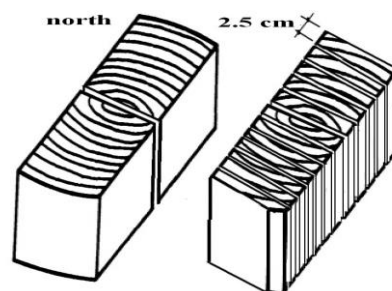

Figure 2. Sawing pattern use for each stem section to obtain specimens for wood colour.

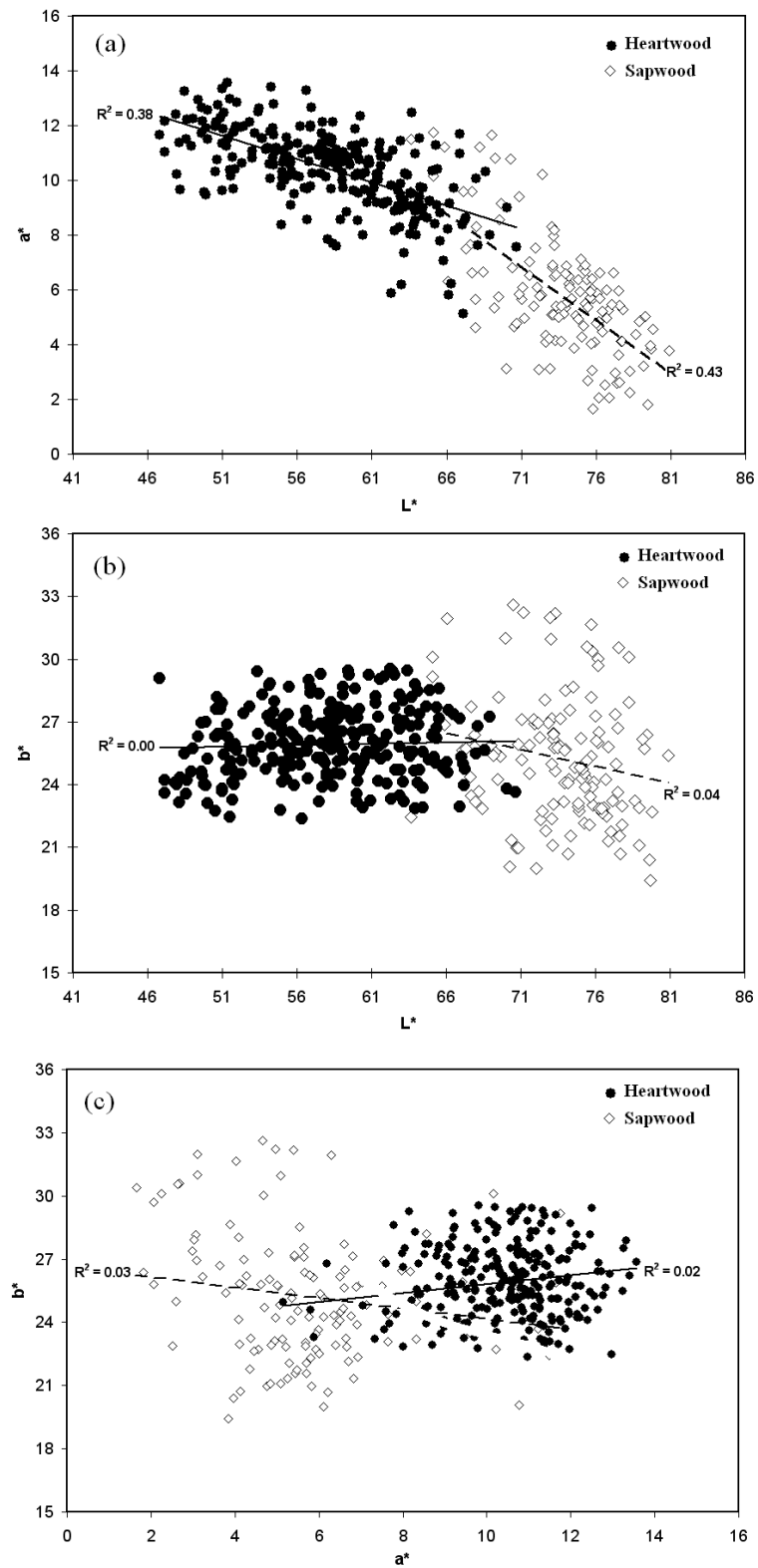

Figure 3. Relationship between L^* vs a^* , L^* vs b^* and a^* vs b^* for *Tectona grandis*, separating heartwood and sapwood.

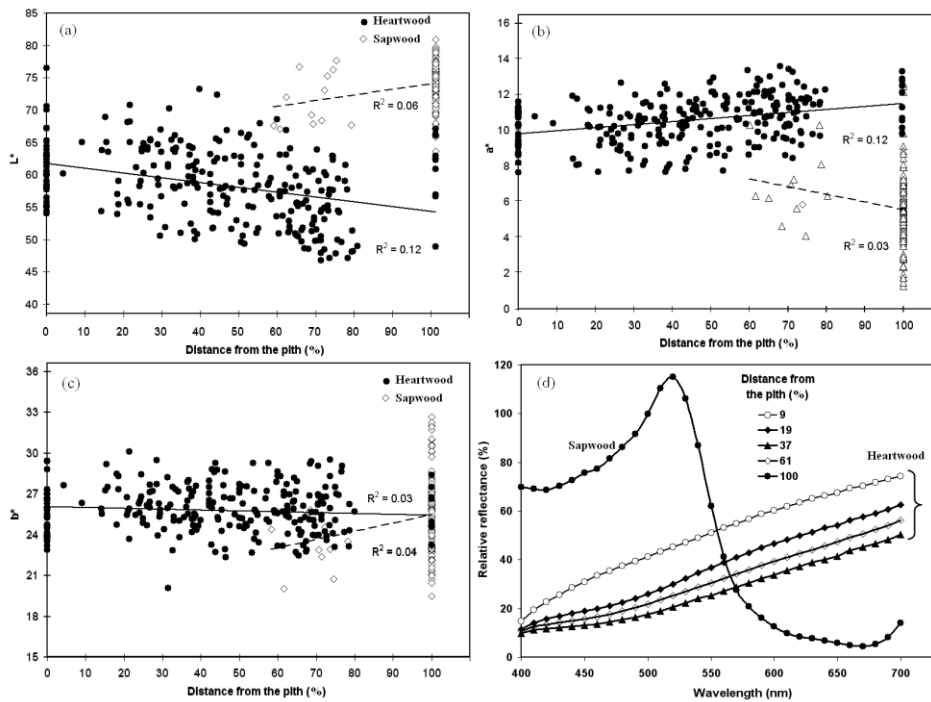

Figure 4. Relationship between distance from the pith and L^* , a^* , b^* for *Tectona grandis*, separating heartwood and sapwood and relative reflectance of heartwood and sapwood.

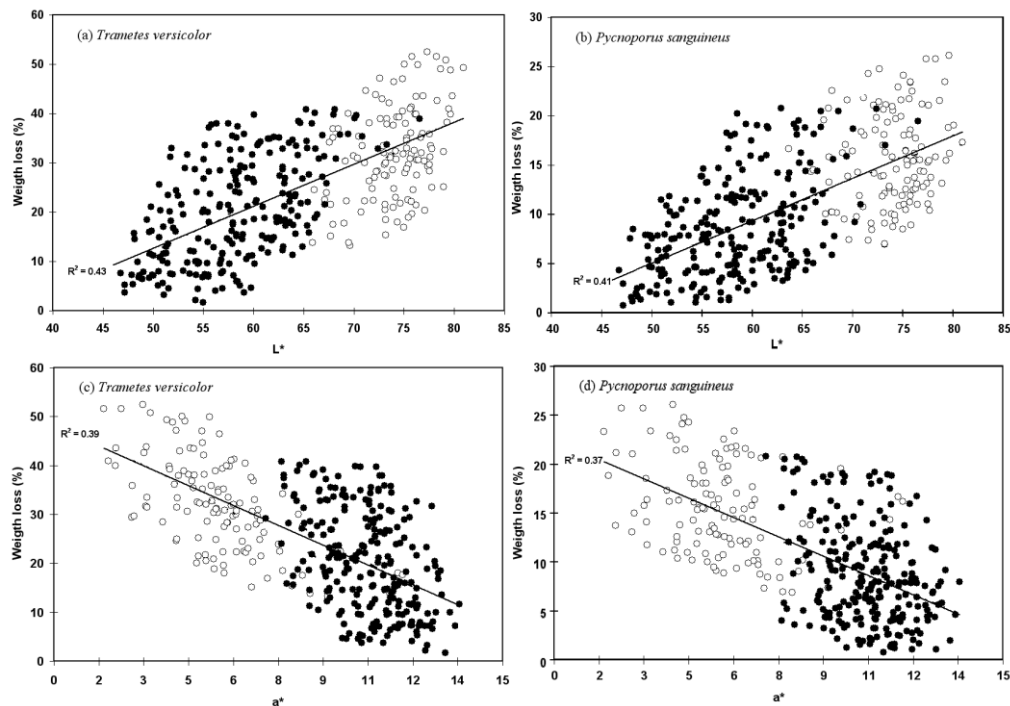

Figure 5. Relationship between L^* and a^* coordinates of *Tectona grandis* wood colour and its weight loss for *Trametes versicolor* and *Pycnoporus sanguineus* white-rot.

- MOYA; R., CALVO-ALVARADO, J. 2009. Variation of wood color parameters of *Tectona grandis* and its relationship with physical environmental factors in Costa Rica.

Forest Ecology and Management (a someter esta revista indexada en los próximos dos meses)

Variation of wood color parameters of *Tectona grandis* and its relationship with physical and chemical soil properties

Abstract

A total of 23 plantations with ages between 7 and 15 years were selected in Costa Rica, covering a wide range of soil fertilities. Depth of the first layer, effective depth, clay, limo, and sand content, apparent density, water retention and water useful percentage, retention at 15 Bars and 0.33% Bars, pH, cation exchange capacity, exchange acidity, and Ca, Mg, K, P, Zn, Cu, Fe and Mn content were analyzed.

The results shown that L^* ranged from 46.8 to 80.9, a^* from 1.9 to 13.6 and b^* from 4.1 to 32.6 in sapwood and heartwood. There was found only a correlation between L^* and a^* , however, low correlation was found in both tissues. L^* and a^* were statically correlated with pith distance for heartwood, but not for b^* . Any correlation was found between sapwood color parameters and soil properties, while the color parameters were correlated with several physical and chemical properties in heartwood. The b^* coordinate was the most correlated variables with soil properties, while that L^* and a^* were less correlated. The multivariate canonical analyzes established 2 significant canonical components with high degree of explanation, approximately 88%. The first component explained the 61.5% of the variability and the second one with 27.0%. The b^* coordinate of wood color was highly correlated with first canonical component, so yellowness/lightness color presence in *T. grandis* is due to almost soil properties. Significant correlation was determined for L^* and a^* at second canonical component, describing so the brown color variation and it influence by some soil properties.

Keywords: CIELab color system, tropical wood, sapwood, hardwood, nutrient uptake

Introduction

The color of wood differs widely among species and also within a tree (Nishino et al. 1998, Liu et al. 2005). It is an important factor when finding uses for wood for end users such furniture and decorative veneers. The wood color appearance had been considered an important at the moment of buying (Vetter et al, 1990, Mazet & Janin, 1990). And different colorimetric systems with accurate methods, for example CIELab color systems, had been implemented to evaluated the wood color variation for growing conduction (Sotela et al. 2008), different species (Nishino et al. 1998, Nishino et al. 2000), genetic aspects (Sotela at al. 2008), drying wood (Möttönen,et al., 2002), decay resistance (Gierlinger at al. 2004) and thermally treated wood (Johansson & Morén, 2006).

On the others hands, *Tectona grandis* Linn F. has been largely planted on many tropical regions including Latin America, Asia, Africa, and Oceania, covering approximately 6 million hectares (FAO 2006). Teak wood is known in the international market by its durability, high resistance to chemicals, and unique esthetical properties (Tewari 1999). Teak is a premier hardwood valued for its golden and brown color (Thulasidas et al. 2006). According with Bhat (1999), four broad groups are established for slow growth or Asia region for teak: (a) uniform golden yellow or brown color typical of west Coast and Myanmar teak, (b) the second is darker in color than first one, commonly grown in drier localities of central parts of India and the third type is uniform grey-brown color produced trees which grow no larger than pole stage and (d) is wood with lighter or more yellowish and uniform color. However, short rotation trees from fast grow plantation generally fetch a lower price in the timber market because the wood is considered inferior in its quality attributes, such color, density mechanical properties (Thulasidas et al. 2006).

In Costa Rica, teak plantations have been planted in large area (Moya & Pérez, 2007) and been managed under new concepts orienting the fast growth and high productivity (Bermejo *et al.* 2004, Perez & Kanninen 2005), therefore trees are felled in short rotation. The high demand for incorporating new planting sites has led to the establishment of plantations on poor soils, resulting in a very low performance, high management costs, and additional deterioration of soils due to high intensive culture practices (Alvarado 2006, Pal & Huse 2006, Webb *et al.* 2006). Other important point about teak wood from trees growing in Costa Rica is that its light brown and large

variation of color wood, therefore this wood is marketed to a low price or it is called “baby teak” (Moya & Pérez, 2007).

Wood color is influenced by many factors including site, environment, stand conditions, management, genetics, and age (Phelps et al. 1983, Rink & Phelps, 1989, Saranpää 2003). Particularly in teak, there are recently reported studies about the causes of variation of teak wood color and its effects in some wood properties. For example, Thulasidas et al. (2006) and Bhat et al. (2005) reported that paler color (less yellowness) and low decay resistance was found wet site and for trees growing in home garden in Kerala-India. Kokutse et al. (2006) showed that heartwood was lightest nearest the pith and darkness (L^*) and redness (a^*) increased towards the outer heartwood and that low decay durability is produced for increasing of lightness (L^*).

Physical and chemical properties of the soil produced variations in wood quality (Rigatto *et al.* 2002). For example, a low wood density may be obtained on sites with favorable soil properties for stand growth (particularly tree diameter) with a consequent low quality for structural uses (Cutter *et al.* 2004). Few studies report the effect of chemical or physical soil characteristics on wood quality, as reviewed by Zobel and Van Buijtenen (1989) for other species different than teak, however they not mentioned wood color variation for soil properties.

In teak, the growing condition had demonstrated relation between wood production and physical and chemical characteristics of soils in different country of Central America. Alvarado & Fallas (2004) and Ugalde *et al.* (2005) indicate that a reduction of 3% occurs in the average stand growth when the pH levels fall below 6, while an optimum growth rate takes place when the calcium level is superior to 68% on teak plantations in Costa Rica and Panama. Recently, Moya and Pèrez (2008) showed that tangential and radial shrinkage were the most correlated variables with the soil characteristics, while the less correlated variables were specific gravity and Volumetric Shrinkage. No detail description of soil properties are reported in studies related to color wood, as “site location” is given as unique reference on most cases. In relation to this, the researches above mentioned (Thulasidas et al. 2006, Kokutse et al. 2006 and Bhat et al. 2005) showed the wood color variation in relation with different growing conditions (site location) but not different soil properties.

Very few studies have been carried out on teak plantations comprehending the relationship of wood color with soil characteristics (physical and chemical properties).

This paper presents compressive results about wood color variation of trees of *Tectona grandis* and it will increased additional information about wood quality from trees growing in fast growth and short rotation plantation. The objective was to established the effect of soil chemical and physical characteristics on wood color measured by CIEL*a*b* color system in trees from fast growth plantation the North region of Costa Rica.

Materials and methods

Study area: A total of 23 plantations with ages between 7 and 15 years were selected in the North and North-West regions of Costa Rica covering a wide range of soil fertilities and climatic conditions. Annual precipitation between 1500 and 5000 mm, an average annual temperature of 20-28 °C, and a strong dry season between January and April in the North-West regions and with a short dry season in February and March in North regions (Bolaños & Watson 1993).

Sample plantations: the 23 sampled plantations were property of three different private companies located within the study area. Stand density varied between 160 and 580 trees per ha. Dasometric variables were obtained from the different samples plots database previously established and continuously measured by the companies (Table 1). Previous result detailed about plantation sampled Moya and Pérez (2008).

Table 1. Average dasometric variables and site locations of each plantation evaluated in the present study.

Site code	Age (years)	Latitude (N)	Longitude (W)	Tree height (m)	Diameter breast height level (cm)	Stand density (trees ha ⁻¹)
1	14	N10°45'42"	W84°27'15"	25.80	25.60	264
2	14	N10°45'35"	W84°27'41"	16.90	16.90	226
3	14	N10°48'43"	W84°26'20"	22.10	25.30	264
4	14	N10°48'52"	W84°25'59"	15.50	16.30	245
5	7	N10°51'21"	W84°29'54"	18.07	19.90	396
6	7	N10°51'16"	W84°30'19"	14.89	15.34	377
7	14	N10°59'03"	W84°45'04"	19.10	22.30	188
8	14	N10°59'09"	W84°45'05"	18.10	25.40	151
9	9	N10°58'46"	W84°44'45"	16.13	19.37	318
10	11	N11°05'24"	W85°27'36"	17.70	21.30	300
11	11	N11°04'48"	W85°27'00"	15.90	18.90	440
12	10	N11°06'36"	W85°28'12"	18.00	22.50	440
13	10	N11°06'00"	W85°28'12"	15.00	18.90	520
14	8	N11°12'00"	W85°35'24"	13.10	17.80	580
15	8	N11°12'00"	W85°36'00"	16.50	21.10	500
16	10	N11°11'24"	W85°37'48"	14.10	18.70	460
17	10	N11°11'24"	W85°37'12"	19.10	25.10	320
18	15	N11°09'36"	W85°41'24"	22.50	26.50	300
19	15	N11°09'00"	W85°41'24"	21.60	24.20	320
20	13	N09°50'49"	W85°10'52"	23.20	25.40	172
21	13	N09°50'18"	W85°11'02"	23.30	27.40	160
22	15	N09°49'19"	W85°14'40"	22.00	23.20	328
23	15	N09°49'56"	W85°14'32"	22.10	24.20	338

Soil study: a soil profile of 1.0 x 1.0 x 1.0 m size was established on each plantation, procuring to place each profile within the most representative site area and next to a sample plot. Samples from the upper layer (first 20 cm) of the soil profile were taken for determining the apparent density (AD), the water retention percentage (WRP), and the water useful percentage (WUP). In addition, the depth of the first layer (D) and effective depth (ED) were determined on each soil profile; samples were taken for further texture and chemical analyses. Texture analysis consisted on the determination of clay (C%), limo (L%), and sand content (S%), AD, WRP, WUP, retention at 15 Bars (RET15), and retention at 0.33% Bars (RET33), according to the methodology of Forsythe (1985). The chemical analysis of the first soil layer was carried out using the methodologies of Briceño & Pacheco (1984), Bertsh (1986), and Diaz-Romeu & Hunter (1978),

commonly implemented in Costa Rica for soil analyses. Potassium chloride (KCl) was used as extracting media for the determination of the exchangeable acidity (EA) and the calcium (Ca) and the magnesium (Mg) content. A specter photometer of atomic absorption "Analisis 300" was implemented for determining the content of phosphorus (P), iron (Fe), manganese (Mn), copper (Cu), zinc (Zn), and potassium (K). The cation exchange capacity (CEC) was measured by specter photometry of AA and the acidity saturation was determined by the exchange acidity.

Sampled trees: a total of 3 average trees (with mean diameter breast height, straight stem, normal branching, and without pests or diseases) were selected from the neighboring areas of each soil profile. North orientation was marked on each tree prior harvesting. From each tree, 5 cm cross-sectional disk was taken at breast height level (1.13 m) and place in plastic bags for further laboratory analysis.

Wood samples preparation: each log was sawn into radial strip of 3 cm width through pith from north to south direction, labeled N and S, respectively (Figure 1). These samples were conditioned at 22°C and 60% relative humidity during several weeks until they reach a moisture content of 11-12%. Then all radial boards were re-sawn in 2.5 cm thick battens radially from centre to bark. Each little sample was labeled and located according radial position in the stem, expressing this location with relative distance of pith. And each sampled was labeled for sapwood and heartwood. Tangential surfaces were sanded to minimize the risk of variation of color values and after 20 hrs the wood color was measured.

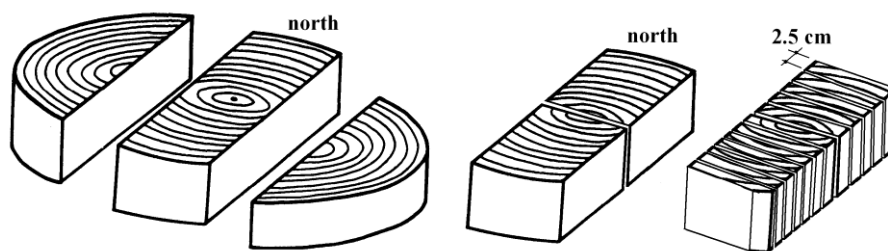

Figure 1. Sawing pattern use on each stem section.

Color measurement: wood colour was measured using a portable Miniscan Hunter lab colorimetric under ambient temperature and humidity of Wood Properties Laboratoraty of Instituto Tecnológico de Costa Rica, Cartago Campus. The colorimeter was calibrated against a white working standard supplied with the instrument each time the instrument was switched on. The reflectance spectra were recorded according to the

standardized CIELab chromaticity system as a function of wavelength. The measuring range was set within the visible range of 400–700 nm at intervals of 10 nm with a measuring aperture of 11 mm. For viewing of reflection, the observer component was included at an angle of 0° to the normal of specimen surface. The standard illuminant D65 (corresponding to daylight at 6500 K) were used as color space measuring and computing parameters. The CIEL*a*b* a color system estimates the value of three variables: Coordinate L* for lightness represents the position on the black–white axis (L=0 for black, L=100 for white), while the chroma value a* defines the position on the red–green axis (positive values for red shades, negative values for green shades), and b* on the yellow– blue axis (positive values for yellow shades, negative values for blue shades). Two measurement were taken each wood sample and average values were obtained for coordinate L*, a* and b*.

Statistic Analysis: the normality and the presence of extreme data or outliers were verified for each color parameters and soil properties. Pearson matrix correlation was applied for coordinates L*, a* and b* and regression analysis and scatter plot were used to show the relationship of these variables for sapwood and heartwood. Pearson matrix correlation was applied again to show the relations between color coordinates for heartwood and physical and chemical soil properties. Finally, we used canonical correlation multivariate analysis between color coordinates in heartwood and soil properties, which is established as a linear combination of two sets of variables so the correlation between both is maximized (Johnson and Wichern 1992). The independent variables were soil properties while the dependent variables were color parameters. Statistical SAS and STATISTICA program were used to evaluate the meaning of the regression model.

Results and discussion

Wood color

The lightness index (L*) ranged from 80.9 to 63.6 in sapwood and from 46.8 to 70.6 in heartwood. The redness index (a*) ranged from 1.9 to 11.7 and 5.1-13.6 for sapwood and heartwood respectively, yellowness (b*) from 19.4 to 32.6 for sapwood and from 4.1 to 29.5 in heartwood. From chemical point of view, the variation of extractives presence or chemical compositions of lignin produced for different soil properties can be explained wood color variation of heartwood (Burtin, 1998). For example, some works shown that redness values (a*) and lightness (L*) are correlated with

extractive contents, while yellow tones of wood are primarily governed by the photochemistry of the essential wood components, particularly lignin.

Table 1 shows the average colorimetry results for the teak wood specimens for sapwood and heartwood of *T. grandis* in CIELab color systems. Note that the values in color coordinates are positive. All objects can be estimate their color by three variables with CIELab: L*=lightness ranging from 0 to 100, 0 being total blackness and 100 pure white, a*= green – red chroma coordinate ranging from -100 to 100, with negative values reflecting the dominance of greenness and positive ones redness, and b*= blue-yellow chroma coordinate ranging from -100 to 100, with negative valued reflecting the dominance of blueness and positive ones yellowness color (Hunterlab, 1995). So, color composition of *T. grandis* wood can be described by combination color of different tonalities of dark, red and yellow. We can note too that the values of L* and b* in sapwood and L*, a* and b* values of heartwood were distributed in a narrow region compare to the possible ranges, the variation coefficients were minor to 12.35% (Table 1). The a* values were distributed in a largest distribution compare to the possible range in sapwood, so the coefficient variation was 33.28% (Table 1). On the other hand, the color composition heartwood and sapwood are different, as expected. Heartwood color is formatted by higher values of L* and lower values of a* in relation to sapwood (Table 1). The change in color between sapwood and heartwood is presumed to be due to oxidation and polymerization of phenolics components in heartwood by chemical or enzymatic process (Burtin et al., 1998, Gierlinger et al, 2004).

Although, lower variation was found in coordinates of CIELab color systems in *T. grandis*, with exception of a* coordinates in sapwood, the wood color variation is considered large for end users (Bhat, 1999). We can explain it because the variation of color space (three-dimensional model) is quadratic addition of difference in each coordinates (Gonnet, 1993). Mazet and Janin (1990), according with researching on 90 French and Italian assessors drawn of woodworking industries and oak-veneer samples, reported that a difference of over 2 unit in $[(L^*-L^*)^2 + (a^*-a^*)^2 + (b^*-b^*)^2]$ is distinguishable to the human eye. For agricultural or horticultural applications is this difference varied from 1.0 to 3.0 (Voss & Hale 1998). So a difference in 1 point in *T. grandis* different samples in all coordinates of color systems will produce a difference in the human eye.

Table 1. Color parameters of *Tectona grandis* growing in Costa Rica with CIELab system.

Wood	L* (lightness)	a* (redness)	b* (yellowness)
Sapwood	73.8 (3.45 - 4.66)	5.8 (1.84 - 33.28)	25.22 (2.95 - 11.70)
Heartwood	58.15 (5.66 - 9.67)	10.4 (1.30 - 12.35)	25.91 (2.21 - 8.54)

Note: the values in parenthesis represent deviations standard and variation coefficients

The L*, a* and b* values obtained in wood from fast-growth plantation of *T. grandis* in Costa Rica are not comparable with others researches. For example, Thulasidas et al. (2006) reported average values of 56.34, 6.85 and 23.44 in L*, a* and b* coordinates, respectively, for wood from trees growing in plantation in India. The Costa Rican teak wood has more lightness and less redness than Indian wood, because there was found that the Costa Rican wood the L* values (lightness coordinates) is more high and a* values (redness coordinates) is minor than Indian wood. However, there results might be consider carefully because, different equipment color was used in both research, we used calorimeter and Bhat et al. (1999) used VU spectrophometer and we can hope difference in wood color determination between equipment (Vetter et al., 1990).

Relation between wood color coordinates

The Figure 2 shows the relation between the color parameters, separating the heartwood and sapwood measuring. There was found only a correlation between L* and a* in sapwood and heartwood (Figure 2). The lower correlation was found in both tissues, $R^2=0.38$ for heartwood and $R^2=0.43$ for sapwood. No significant correlation was found L* and b* (Figure 2b) and between b* and a* (Figure 2c). This results show that the variation in wood color of *Tectona grandis* is produced by inverse variation between L* and a* coordinates, black and redness, respectively. Nishono et al. (1998) measured the correlation between different color parameters of many tropical species from Guiana. The relationships between L* and a* and not statistically scientifically relation between a* and b* found in this tropical species agreed with *T. grandis* results. However, relation between a* and b* in Guiana wood disagreed with ours results, it was found relationship. Another hardwood *Fagus sylvatica*, but from temperate climatic, it found that the parameters of CIEL*a*b* color systems were correlated (Liu et al., 2005), L* with a*, L* with b* and a* with b*. Results different with *T. grandis* that L* a* correlation was found.

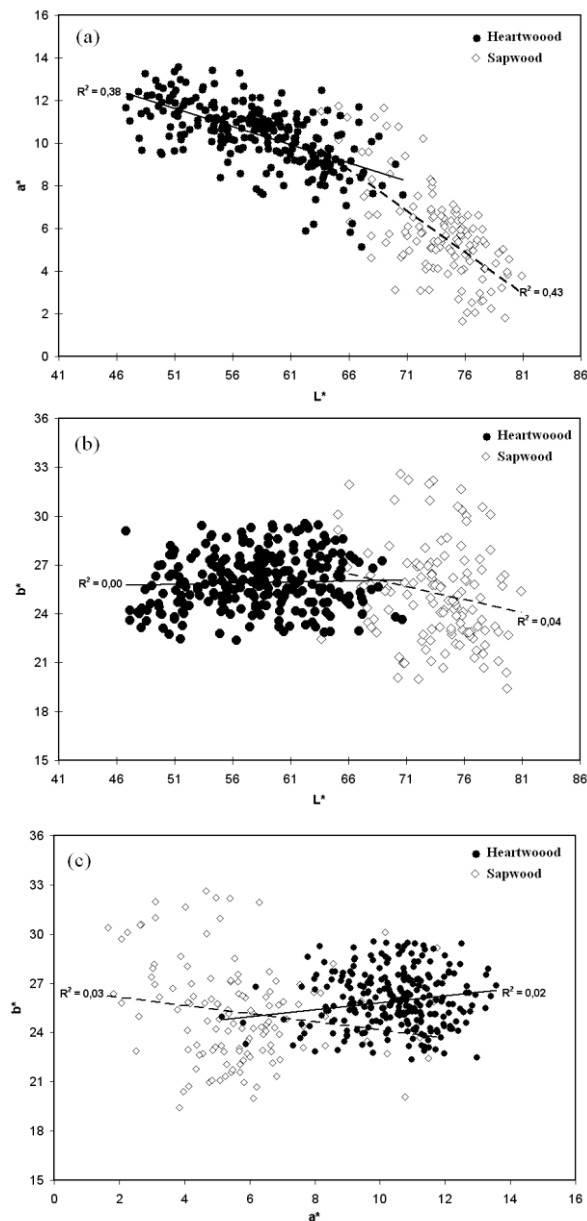

Figure 2. Relationship between L* vrs a*, L* vrs b* and a* vrs b* for *Tectona grandis*, separating heartwood and sapwood.

Wood color variation with pith distance

The color coordinates L* and a* were statically ($\alpha=0.05$) correlated with pith distance for heartwood and not correlation found in sapwood for any color parameters and pith distance (Figure 3). However, low correlation coefficient were found in heartwood, $R = -0.36$ for relationship of L* with pith distance and $R = 0.36$ for relation relationship between a* with pith distance (Figure 3). The coordinates b* not significant correlation was found (Figure 3c). According with these results, the heartwood color is lightest and lowest redness near to pith and with increasing of pith distance, the wood is less

light and redness increased. Kokutse et al. (2006) with teak trees grown in Togo in fast-growth plantation agreed with wood color variation found for teak trees growing in Costa Rican plantation, color variation with pith distance for L^* and a^* parameters for CIE color systems and not significant difference in b^* color parameters.

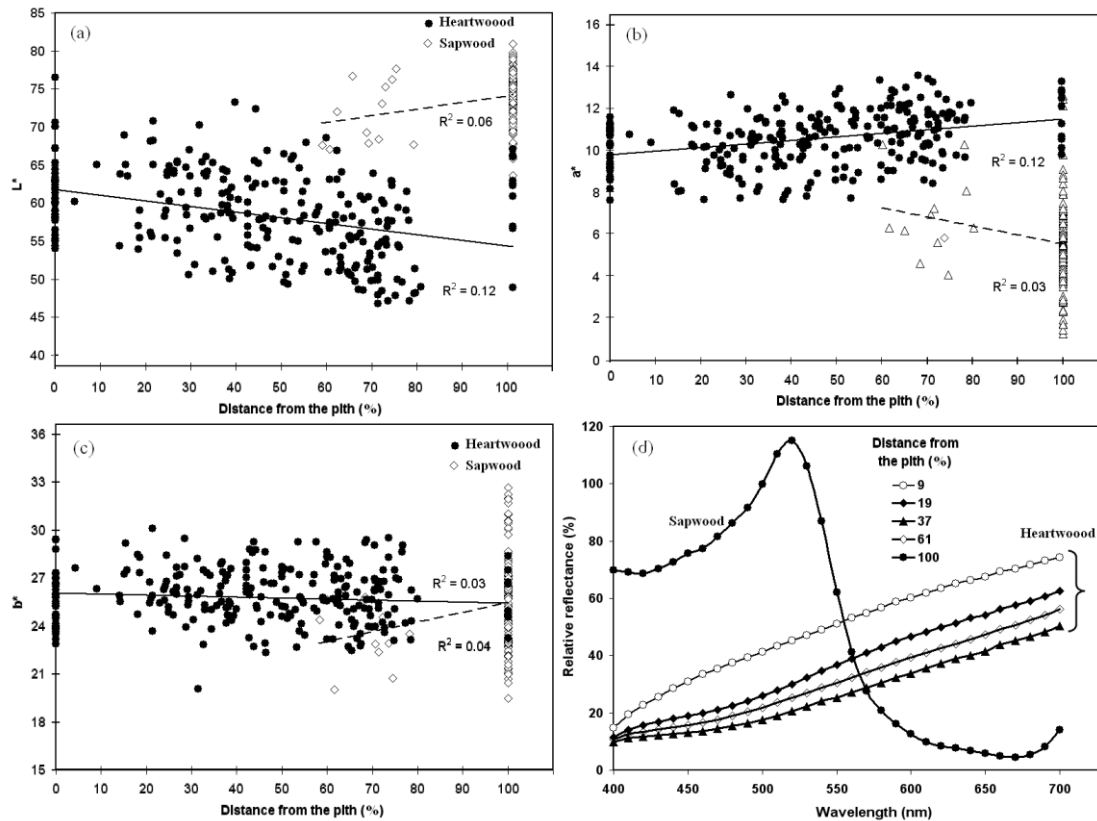

Figure 3. Relationship between distance from the pith and L^* , a^* , b^* vs for *Tectona grandis*, separating heartwood and sapwood and relative reflectance of heartwood and sapwood.

Effect of soil properties on wood color

Any correlation was found between sapwood color parameters and soil properties, while the color parameters were correlated with several physical and chemical properties in heartwood (Table 2). The b^* coordinate of wood color, was the most correlated variables with soil properties. All physical properties and pH, Ca, Mg, CEC, AS, P, Zn and Fe in chemical properties affected significantly this coordinate. EA, K and Cu were chemical soil properties that not correlated with b^* . While the less correlated coordinates of wood color were L^* and a^* . Multiple correlation analysis showed that correlation between CIELab parameters and soil characteristics were roughly explained by the different model parameters ($r < 0.514$). Noted that low correlation were measured between L^* and a^* and soil properties, the correlation coefficient is minor to 0.206 (Table 2). Correlation coefficients were highly significant

($\alpha=0.05$) but low correlation (<0.514). On the other hands, physical properties (D, Ret33, WUP, AD and L%) were statically significant with a^* color coordinates of sapwood and K of all physical and chemical properties was significant with b^* coordinates of sapwood. However, a weak correlation ($R<0.338$) was found in these relations, Any significant relation between soil properties and L^* color coordinate was found for sapwood (Table 2).

Table 2. Pearson correlation coefficients for the relationship between color parameters in heartwood of *Tectona grandis* and soil characteristics.

	Variable	CIELab parameters in heartwood			CIELab parameters in Sapwood		
		L^*	a^*	b^*	L^*	a^*	b^*
Physical characteristics	D	-	-	0.514**	-	-0.321**	-
	ED	-	-	0.436**	-	-	-
	Ret33	-0.156*	-	-0.301**	-	0.338**	-
	Ret15	-	-	0.251**	-	-	-
	WUP	-0.190*	-	-0.425**	-	0.345**	-
	AD	-	-	0.435**	-	-0.245*	-
	S%	-	-	-0.400**	-	-	-
	L%	-	-	0.246**	-	-0.246*	-
	C%	-	-	0.277**	-	-	-
Chemical characteristics	<i>pH</i>	0.206*	-0.195*	0.167*	-	-	-
	EA	-	-	-	-	-	-
	Ca	-	-	0.448**	-	-	-
	Mg	-	-	0.368**	-	-	-
	K	0.150*	-0.168*	-	-	-	-0.253*
	CEC	-	-	0.439**	-	-	-
	AS	-	-	-0.316**	-	-	-
	P	-	-	-0.441**	-	-	-
	Zn	-	-	0.238*	-	-	-
	Cu	-	-	-	-	-	-
	Fe	-	-	-0.429**	-	-	-
Mn	-	-	-	-	-	-	
Characteristics of plantation	Tree age	-0.417**	0.405**	-0.201*	-	0.251*	-
	DBH	-0.249*	0.313**	0.194*	-	-	-
	TH	-	-	-	-	-	-
	PD	0.392**	-0.504**	0.284**	-	-0.263*	-

Note: missing values correspond to no statistically significant values. **Legend:** ** Statistically significant at 99% confidence; * Statistically significant at 95% confidence. **(Soil physical characteristics)** D: depth of first layer; ED: Effective depth (of soil); Ret33: water retention at 0.33% Bars; Ret15: Water retention at 15 Bars; WUP: Water utility percentage; AD: Apparent density (of soil); S%: Sand percentage; L%: Limo percentage; C%: Clay percentage. **(Soil chemical characteristics)** EA: Exchange acidity; CEC: Cation exchange capacity; AS: Acid saturation (%); variables in italic correspond to chemical elements. **Plantation characteristics:** TA: tree age, DBH: diameter at breast height, TH: Tree height and PD: Plantation density.

The low correlation coefficients suggest that wood color in *T. grandis* cannot be fully explained by soil characteristics and that other factors may have a larger influence on them (genetics, growth rate, plantation management, dry season periods, precipitation, climate). In fact, tree age, DBH and density of plantation (tree hectares⁻¹) shown

significant correlation with color parameters (Table 2). However, low correlations coefficient was found ($R < 0,504$). Such relationships were found for various others species, e.g. Gardner and Barton (1960) found that redness hue increased with age of the heartwood. Gierlinger et al (2004) with the hybrids of Japanese larch shown that old trees had significant redder hue (a^*) than young trees. Klumpers et al, (1992) found that the heartwood became increasingly redder (a^* coordinate) with the age of *Quercus robur* trees. On the others hand, the growth rate was negatively correlated yellow hue (a^*), but not with L^* or b^* in *Calycophyllum spruceanum* growing the Peruvian Amazon (Sotela et al, 2008). Wilkins and Stamp (1990) reported that faster growing trees of *Eucalyptus grandis* produced redder heartwood (increasing of a^* coordinate). Rink (1987) found that faster growing trees of *Juglans nigra* produced lighter color colored heartwood.

Additionally, the wood color is influenced by genetic factors and it was not consider in this studies. There are a few studies about the genetic effects on wood color in tropical species. Sotela et al., (2008) for *Calycophyllum spruceanum*, for example, reported that wood color had relatively low heritability for L^* color parameter and not significant correlation was determined for a^* and b^* coordinates.

Multivariate analysis by canonical correlation in heartwood

The analysis of multivariate canonical correlation showed that the variations of the coordinates of wood color (L^* , a^* and b^*) of *T. grandis* trees growing in North part of Costa Rica can be explained by physical and chemical soil properties (Table 3). The model of canonical correlation between the coordinates of wood color and soil properties established 2 significant ($P < 0.01$) canonical components with high degree of explanation, approximately 88%. The first component explained the 61.5% of the variability and the second one a 27.0%. There are third canonical component, but it was significant at $\alpha = 0.05$, with low correlation coefficient and 11.5% if the variance (Table 3).

Table 3. Statistical parameters of canonical correlation between color parameters (L^* , a^* , b^*) and soil properties in heartwood of *Tectona grandis* trees growing in Costa Rica (N=267).

Canonical components	Canonical Correlation	Eigen value	Percentage of variance	Accumulate variance	L. ratio	Approx F	Num df	P valor
1	0.681	0.869	0.615	0.615	0.333	4.261	573	<0.0001
2	0.526	0.381	0.270	0.885	0.622	2.720	386	<0.0001
3	0.375	0.163	0.115	1.000	0.860	1.761	194	0.032

In the U1 axes of canonical component 1 with 15.5% of variance has highly positive correlations with b* coordinate (R=0.99) and its corresponding vector V1 was highly significant with all physical and chemical properties of the soil, except EA, K and Cu. However high correlations (R>0.60) were determined for D, ED, WUP and AD for physical properties and Ca, CICE, P and Fe for chemical properties. Positive correlation was found for D, ED, AD, Ca and CICE and negative correlation in WUP, P and Fe. The correlations values between U1 vector with others soil properties (Ret33, Ret15, %S, %L, %C, pH, Mg, SA and Zn) were minor than 0.6 (Table 5). For the U2 axes of canonical component with 14.1% of variance had positive correlation with L* wood coordinate and negative correlation with a* wood color coordinate. High correlations coefficients were found, with 0.904 and -0.837 respectively (Table 5). The vector V2 was highly correlated with Ret33, WUP and S% for physical properties and pH, EA, Ca, K, CICE, SA, Fe and Mn for chemical properties. However, low values of correlation coefficients (R<0.405) were determined in all soil properties (Table 5). Positive correlation were determined pH, Ca, K and CICE and the others ones were negative.

Table 5. Correlations between the variables and canonical components in heartwood of *Tectona grandis* trees growing in soil fertility in Costa Rica (N=267).

Variables	Canonical components 1		Canonical components 2		
	U1	V1	U2	V2	
Color parameters	L*		0.904**	0,475**	
	a*		-0.837**	-0,440**	
	b*	0.989**	0.675**		
Physical characteristics	D	0.517**	0.758**		
	ED	0.432**	0.633**		
	Ret33	-0.292**	-0.428**		-0,285**
	Ret15	0.257**	0.377**		
	WUP	-0.420**	-0.616**	-0.163*	-0,311**
	AD	0.422**	0.619**		
	S%	-0.395**	-0.580**		-0,237**
	L%	0.240**	0.353**		
	C%	0.274**	0.402**		
	pH	-0.196**	-0.287**	0.213**	0,405**
Chemical characteristics	EA			-0,245**	
	Ca	0.435**	0.638**		0,178**
	Mg	0.355**	0.521**		
	K			0.188**	0,358**
	CICE	0.426**	0.624**		0,162*
	SA	-0.352**	-0.517**	-0.176*	-0,335**
	P	-0.440**	-0.645**		
	Zn	0.243**	0.357**		
	Cu				
	Fe	-0.410**	-0.601**		-0,211**
Mn				-0,208**	
Variance	0.466	2.442	0.422	0.168	
% variance	0.155	0.116	0.141	0.008	
Variance cumulative	0.155	0.116	0.296	0.124	

According with these results, we can explain the canonical components with: the b^* coordinate of wood color was highly correlated with first canonical component, so yellowness/lightness color presence in *T. grandis* is due to almost soil properties. Significant correlation was determined for L^* and a^* at second canonical component, describing so the brown color variation and it influence by some soil properties (Ret33, WUP, S%, pH, EA, Ca, K, CICE, SA, Fe and Mn). The Figure 4, which shows canonical scores for U and V of the canonical component 1 and 2, confirmed the relationships above mentioned. The U1 (b^* coordinate variation) increased with scores of soil properties or V1 scores ($R^2=0.597$). The scores of U2 (L^* and a^* coordinates variation) increased too with scores of soil properties (V2), but low determination coefficient values was found ($R^2=0.282$).

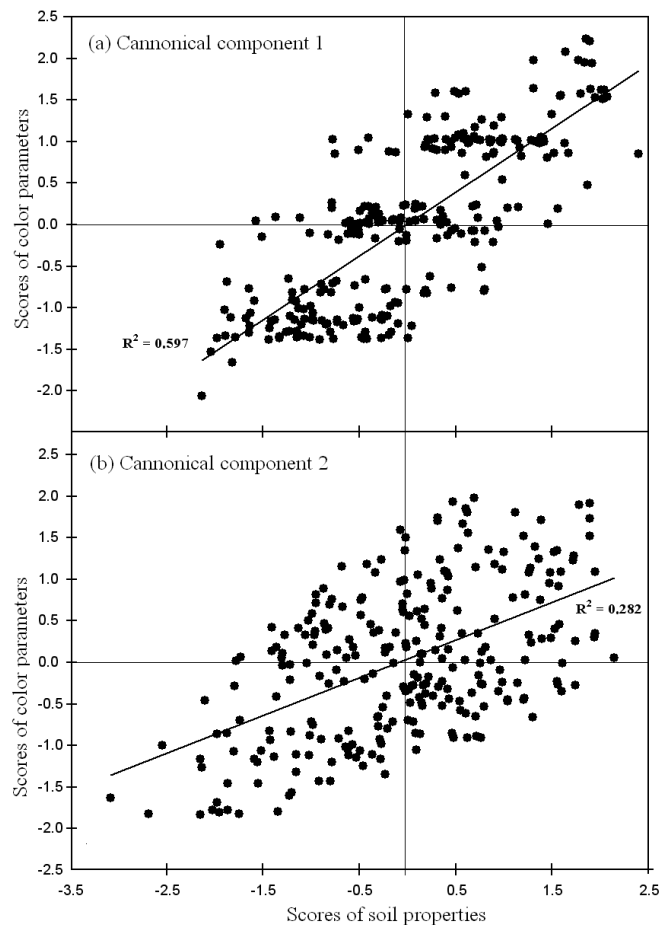

Figure 4. Relationship of scores of color parameters and scores soil properties for *Tectona grandis* growing in different soil fertility in Costa Rica.

Little researches show that soil properties produced different color characteristics in wood. For example, much representative researches about effect of soil properties on wood color are carry out for Maeglin and Nelson (1970), Nelson et al (1969) for *Juglans nigra* growing in North America. They found that variations in soil fertility for different soil properties were correlated with difference in wood color and poorer site showed a

tendency toward darker and redder heartwood. Other important relations were that P, exchangeable K, Ca, Mg, and total N and pH were the most important soil properties which are related with wood color. They noted also that the relationship of heartwood color to soil properties was greater than it was either to tree age or to diameter-growth rate. Phelps et al (1983) found that luminance, (They not measured wood color by CIElab color systems) for wood from sites with difference physical and chemical properties was different, however they did not explained what soil properties affected wood luminance.

Bhat (1999) and Thulasidas et al. (2006) that mentioned that golden yellowish brown color had wide reputation in the world trade, however the heartwood produced per fast grown plantation is difficult to reach this color. The better wood color in this wood had not reported in CIElab coordinates. According with research of Keey (2005), Janin et (2001), Nishino et (1998) that suggested darker or brown color is obtained when a^* value is over 10 and liveness (L^*) is inferior than 54. However, they not mentioned about yellowness color parameter (b^*). We supposed that yellowish brown color is obtained in *T. grandis* when the highest values were found for redness parameter (a^*), lowest values in lightness (L^*) and highest values for yellowness (b^*). According with this supposition, some soil properties can produced wood with optimum color wood (high values in a^* and b^* and low L^*) for international market of *Tectona grandis*, and so better wood price are obtained. Multivariate Canonical analyze shown that the first components included yellowness parameter and second one described the brown parameter. So the lowest values of b^* can be obtained when increase D, ED, Ret15, AD, L%, C%, Ca, Mg CICE and Zn, but the increasing of Ret33, WUP, S%, pH, P, SA and Fe decrease yellowness parameter. However, it was demonstrated that D, ED, WUP, AD, Ca, CICE, P and Fe were soil properties with the highest correlation coefficient ($R > 0.61$), suggesting a mayor effect in the yellowness parameter. There is an increment in brown color of *T. grandis* wood with increment of pH, Ca, K and CICE in the soil, but the increment of Ret33, WUP, S%, EA, SA, Fe and Mn produce wood with less brown color.

Ours results in relation wood color of *T. grandis*, suggest that much of the wood color variations in *Tectona grandis* occurred by different physical and chemical composition of soil (Table 2 and 5), different wood position in trees (Figure 3) and plantation conditions like tree age, DBH and plantation density (Table 2). However, many relationships between soil properties and others effects what affect wood formation must be explored. For example soil properties were relationed with climatic conditions

as temperature or rainfall distribution on years, As well, sites with different classification (poorer or better site or others classification) are produced for variation of physical and chemical in the soil and can be produced wood with different color qualities.

This research was based in different physical and chemical properties, and although others properties what can be affected tree growth were not considered, it is possible that a soil analysis before trees planted may aid forester in determining what color the can achieve from *T. grandis* trees on a given soil. As well, they can control wood color by soil manipulation by fertilization or other soil management techniques.

Acknowledgements

The authors wish to thank The Research Vice-Rector of the Technological Institute of Costa Rica (ITCR), and Precious Woods of Central America (MACORI), Ecodirecta Groups and Panamericans Woods for financial support in soil analyses.

References

- Alvarado, A. 2006. Nutrición y fertilización de la teca. *Informaciones Agronómicas* 61: 1-8.
- Alvarado, A. & Fallas, J.L. 2004. La saturación de acidez y el encalado sobre el crecimiento de la teca (*Tectona grandis* L.f.) en suelos ácidos de Costa Rica. *Agronomía Costarricense* 28(1): 81-87.
- Bhat, K.M., 1999. Is fast grown teak inferior in wood quality –An appraisal of wood figure (colour, grain, texture) from plantations of high input management. *Wood News* 9 (4): 48-49.
- Khat, K.M., Thulasidas, P.K., Florence E.J.L., 2005. Wood durability f home-garden teak against brown-rot and white-rot fungi. *Tree* 9: 654-660.
- Bermejo, I., Cañellas, I. & San Miguel, A. 2004. Growth and yield models for teak plantations in Costa Rica. *Forest Ecol. Manag.* 189: 97-110.
- Bertsh, F. 1987. Manual para interpretar la fertilidad de los suelos de Costa Rica. San José, Costa Rica. Universidad de Costa Rica.
- Bolaños, R. & Watson, V. 1993. Mapa ecológico de Costa Rica. Según el sistema de clasificación de zonas de vida del mundo de L. R. Holdridge. Escala 1: 200.000. Centro Científico Tropical, San José, Costa Rica.
- Briceño, J. & Pacheco, R. 1984. Métodos analíticos para el estudio de suelos y plantas. San José, Costa Rica. Editorial de la Universidad de Costa Rica.
- Burtin, P., Jay-Allemand, C., Charpentier, J., Janin, G. 1998. Natural wood colouring process in *Juglans* sp. (*J. regia* and hybrid *J. nigra* 23 x *J. regia*) depends on native

- phenolic compounds accumulated in the transition zone between sapwood and heartwood. *Trees* 12: 258-264.
- BYK-Gardner, 2004. CIE L*a*b* system. Color-guide 45/0 operating instructions, MD, USA, 1-67.
- Cutter, B.E., Coggeshall, M.V., Phelps, J.E. & Stokke, D.D. 2004. Impacts of forest management activities on selected hardwood wood quality attributes: a review. *Wood Fiber Sci.* 36: 84-97.
- Diaz-Romeu, R. & Hunter, A. 1978. Metodología de muestreo de suelos, análisis químico de suelos y tejido vegetal e investigación en invernadero. Turrialba. Costa Rica.
- FAO. 2006. Global planted forest thematic study: results and analysis, by Del Lungo, J.B. & Carle, J. Planted Forests and trees: Working paper 38. Rome.
- Gardner, J.A., Barton, G.M. (1960). Dihydroquercetin in Douglas-fir and Western larch. *For. Prod. J.* 10: 171-173.
- Gierlinger, N., Jacques, D., Gradner, M., Wimmer, R., Schwanninger, M., Rozenberg, P., Pâques, L.E., 2004. Colour of larch heartwood and relationships to extractives and brown-rot decay resistance. *Trees* 18: 102-108.
- Gonnet, J.-F. 1993. CIELab measurement, a precise communication in power colour: an example with carnation (*Dianthus caryophyllus*) cultivars. *J. Hort. Sci.* 68: 499–510.
- Hunterlab, 1995. Use measurement of appearance. A welly-Interscience publication, Welly and Sond, New York.
- Johansson, D., Morén, T., 2006. The potential of colour measurement for strength prediction on thermally treated wood. *Holz als. Roh. Werstoff* 64: 104-110.
- Johnson, R.A. & D.W. Wichern. 1992. Applied multivariate statistical analysis. 3.ed. MacGraw-Hill, New York, USA.
- Klumpers, J., Janin, G., Berker, M., Lévy G., 1993. The Influences of age, extractive content and soil water on wood color in oak: the possible genetic determination of wood color. *Ann. Sci, For.* 50 (Suppl.1): 403s-409s
- Kokutse, A.D., Stokes, A., Baillères, H., Kokou, K., Baudasse, C. 2006a. Decay resistance of Togolese teak (*Tectona grandis*) heartwood and relationship with colour. *Trees* 20: 219-223.
- Liu, S., Loup, C., Gril, J., Dumonceaud, O., Thibaut, A., Thibaut, B., 2005. Studies on European beech (*Fagus sylvatica* L.). Part 1: Variations of wood color parameters. *Ann. For. Sci.* 62: 625-632.
- Maeglin, R.R. and Nelson, N.D., 1970. Surface Soil Properties of Black Walnut Sites in Relationship to Wood Color. *Soil. Sci. Soc. Am. J.* 34: 142-146.

- Möttönen, V., Alvila, L. and Pakkanen, T. T., 2002. CIEL *a*b* measurements to determine the role of felling season, log storage and kiln drying on coloration of silver birch wood. *Sand. J. For. Res.* 17: 179-191.
- Mazet, J.F., Janin, G., 1990. La qualité de l'aspect des placages de Chênes (*Quercus petraea* and *Quercus robur*): mesures de couleur et critères de d'appréciation des professionnels français et italiens. *Ann. For. Sci.* 47(3) : 255-268.
- Moya, R., Pérez, D., 2007. Processing and marketing of teakwood products from fast-grown teak plantations in Costa Rica. In Nair, K. K. N., K. V. Bhat, V. Anitha. Abstracts Products and Marketing of teak wood products of planted forest. Regional Workshop Products and Marketing of teak wood products of planted forest. 25-28. September 2007. KFRI, Peechi, India. Pag. 24.
- Moya, R., Pérez, D., 2008. Effect of physical and chemical soil properties on wood characteristics of *Tectona grandis* plantations in Costa Rica. *J. Trop. Forest Sci.* 20(4): 147–155.
- Nelson, N.D., Maeglin, R.R. and Wahlgren, H.E., 1969. Relationship of Black Walnut Wood Color to Soil Properties and Site. *Wood Fiber* 1: 29-37.
- Nishino, Y., Janin, G., Chanson, B., Détienne, P., Gril, J., Thibaut, B., 1998. Colorimetry of wood specimens from French Guiana. *J. Wood Sci.* 44:3-8.
- Nishino, Y., Janin, G., Yamada, G., Kitano, D., 2000. Relations between the colometric values and densities of sapwood. *J. Wood Sci.* 46:267-272.
- Pal, M. & Husen, M. 2004. Effect of nitrogen, phosphorous and potassium application to stock plants on nutrient status of coppice shoots of teak (*Tectona grandis* Linn. f.). *Ann. Forestry* 12: 22-28.
- Phelps JE, McGinnes EA Jr, Garrett HE, Cox GS (1983) Growth-quality evaluation of black walnut wood. Part II—color analyses of veneer produced on different sites. *Wood Fiber Sci* 15:177–185.
- Perez, D. & Kanninen, M. 2005. Stand growth scenarios for *Tectona grandis* plantations in Costa Rica. *Forest Ecol. Manag.* 210: 425-441.
- Rigatto, P.A., Dedecek, R.A. & Monteiro de Matos, J.L. 2004. Influência dos atributos do solo sobre a qualidade da madeira de *Pinus taeda* para produção de celulose kraft. *Revista árvore* 28: 267-273.
- Rink G, (1987). Heartwood color and quality variation in a young black walnut progeny test. *Wood Fiber Sci.* 19: 93-100.
- Rink G, Phelps JE (1989) Variation in heartwood and sapwood properties among 10-year-old black walnut trees. *Wood Fiber Sci* 21:177–182
- Saranpää, P. 2003. Wood density and growth. in J.R. Barnett & Jeronimidis, G. eds. *Wood quality and its biological basis*. Blackwell Publishing Ltd., Oxford, UK.

- Sotela, C., Hernández, R.E., Beaulieu, J., Weber, J. 2008. Genetic variation in wood color and its correlations with tree growth and wood density of *Calycophyllum spruceanum* at an early age in the Peruvian Amazon. *New forest* 35: 57-73.
- Tewari, D.N. 1999. A monograph on teak (*Tectona grandis*). International Book Distrutors. Dehra Dun.
- Thulasidas, P.K., Bhat, K.M., Okuma, T. 2006. Heartwood colour variation in home garden teak (*Tectona grandis*) from wet and dry localities of Kerala, India. *J. Trop. Forest Sci.* 18: 51-54.
- Ugalde, L., Alvarado, A., Verjans, J.M., Mollinedo, M. & Rudy, L.C. 2005. Soil-tree relationship and site factors in young teak (*Tectona grandis*) plantations in the Western zone of the Panama Canal. *Revista Agronomía Costarricense* 28: 81-87.
- Voss, D. H. & Hale, W. N. 1998. A comparison of the three editions of the Royal Horticultural Society Colour Chart. *HortScience* 33: 13–17.
- Vetter, R.E., Coradin, V.R., Martino, E.C., Camargos, J., 1990. wood colour – A comparison between methods. *IAWA Bull.* 11: 429-124.
- Wilkins, P. and Stamp, C. M. 1990. Relationship between wood colour, silvicultural treatment and rate of growth in *Eucalyptus grandis* Hill (Maiden). *Wood Sci. Tech.* 24(4): 297-304.
- Webb, M.J., Reddell, P., Nath, S. & Srivastava, R.J. 2006. Determining P and N status of a tropical timber species (teak): Assessment of 'quick' chemical tests and a root phosphatase assay. *Develop. Plant Soil Sci.* 92: 706-707.
- Zobel, B. & Van Buijtenen, B. 1989. *Wood Variation: its causes and control*. Springer Verlag, New York.

MOYA; R., MARIN, D., MURILLO, O., LEANDRO, L. 2009. Genetic study of several physical properties, wood color, decay resistance and stiffness of *Tectona grandis* clones. *Silve genetica* (a someter esta revista indexada en los próximos dos meses)

Genetic study of several physical properties, wood color, decay resistance and stiffness of *Tectona grandis* clones

INTRODUCCIÓN

Entre las especies forestales tropicales, la teca (*Tectona grandis*) se ha convertido en una de las mas importante en el mercado debido a las cualidades físicas, mecánicas y estéticas de su madera (TEWARI, 1999). Se estima que cerca de 6 millones de hectáreas han sido plantadas extensamente en Asia, África, Oceanía y Latino América (FAO, 2006). Su susceptibilidad de manejo de plantaciones silvicultural (KANNINEN et al., 2004; PÉREZ y KANNINEN, 2003, 2005), sus excelentes propiedades de trabajabilidad (MOYA and PÉREZ, 2007), su excelente calidad de durabilidad (TEWARI 1999) y su color tan apetecido de la madera ha permitido que en la actualidad esta sea una de las especies tropicales de plantación más importantes en el mercado (GOH and MONTEUUIS, 2005). Aunado a ello, con el recientemente desarrollado paquetes tecnológicos para su producción y transformación de madera provenientes de plantaciones ha permitido a esta especie ser una de las mas importante en la reforestación en las zonas tropicales (MONTEUUIS and MAÎTRE, 2006).

En Costa Rica dicha especie se ha plantado en 25.600 ha (MOYA and PÉREZ, 2007), y orientadas todas estas a obtener un ciclo corto para su aprovechamiento (SCHMINCKE, 2000). Esta situación dio como consecuencia que dicha madera proveniente de Costa Rica sea conocida "baby teca", la cual tiene entre sus particularidades es que presenta un color café claro y de baja durabilidad al ataque de hongos e insectos, dando como resultado un bajo precio a la madera de plantaciones (MOYA and PÉREZ, 2007). Dicha situación ha llevado a que las empresas y a los investigadores busquen nuevas formas de desarrollar procesos orientados a mejorar la calidad de la madera y por supuesto la producción. Una de las herramientas más usadas es la reproducción de material vegetal a través de la clonación ya que esta permite copiar las condiciones óptimas de un individuo hacia otro (MONTEUUIS and GOH, 1999, MONTEUUIS and MAITRE, 2006). Esta técnica surge debido a que la reproducción sexual presenta algunas desventajas como la baja cantidad de semillas y su baja tasa de germinación (KJÆR et al., 2000), el

período requerido para la etapa de floración y producción de semillas es prolongada (NADGAUDA, et al., 2003). Así mismo existe una variabilidad significativa en ciertas características de importancia económica, tales como el crecimiento, la forma y algunas propiedades tecnológicas y estéticas de la madera (GOH and MONTEUUIS, 1999; MONTEUUIS and MAÎTRE, 2006,).

Algunas investigaciones relacionadas al mejoramiento genético de *T. grandis* se orientan al estudio de la forma y características del árbol. Algunos de estos han demostrado que existe una heredabilidad en el diámetro, la altura del árbol y su periodo de floración (ANDREW and COLLINS, 2008). Al respecto varios autores (GOH and MONTEUUIS, 2005; GOH et al., 2007; MONTEUUIS and MAÎTRE, 2006) mencionan que estos parámetros fenotípicos y otras características del árbol como rectitud e inserción de las ramas, los principales parámetros utilizados en la selección de individuos propicios para la clonación, sin embargo la clonación debe ser refinada con el análisis de las características de la madera. Situación que hasta el momento no han sido evaluados. No obstante algunas investigaciones intentan incorporar algunos conceptos de la calidad de la madera, tales como la heredabilidad del duramen, espesor de la corteza del duramen y contenido de calcio y sílice, elementos anatómicos, durabilidad de la madera y densidad de la madera (KJÆR et al., 1999 and 1996; VARGHESE et al., 2000). Sin embargo es de notar en todos estos estudios que se basan principalmente en ensayos de procedencias y no relacionados a la clonación de la *T. grandis*.

En general a la madera de *T. grandis* es conocida por su buena estabilidad dimensional (relacionado a las contracciones), su durabilidad natural en la madera de duramen, las cualidades estéticas () y sus particulares relacionados al peso específico y propiedades tecnológicas (TEWARI, 1999). En la actualidad el color de la madera es considerado un atributo importante en la fase de comercialización de maderas provenientes de plantaciones (MAZET and JANIN, 1990; THULASIDAS et al., 2006). El color de la madera se ve influenciado por muchos factores, entre ellos factores ambientales, factores genéticos y las condiciones de manejo de las plantaciones y la edad (PHELPS et al., 1983, SARANPÄÄ, 2003). Estudios recientes en teca muestran que la variación del color en relación con su durabilidad (BHAT et al., 2005; THULASIDAS et al., 2006). Aunque estudios de la influencia genética sobre el color de teca no se encuentran en la literatura, estudios realizados en otras especies muestran resultados poco concordantes. Mientras que la especie como *Calycophyllum spruceanum* y *Juglans nigra* reportan una heredabilidad del color (RINK, 1987; SOTELO

et. al 2008), en otras especies como *Quercus petraea*, *Quercus robar* y *Pecea abies* no se encontró que el color de la madera es heredable (HANNRUP et. al., 2004, MOSEDALE et. al., 1996).

Otras propiedades de la madera, tales como las contracciones, densidad, su durabilidad y su resistencia mecánica han recibido gran interés en el mejoramiento y clonación de distintas especies (ZOBEL and JETT, 1995), pero nuevamente una carencia de información en la madera de teca (NADGAUDA et al., 2003). En este sentido, en reciente investigaciones llevada a cabo en el mejoramiento de genético de especies plantados o en plantas importante en la agricultura (CILAS, et al., 2006), la utilización o determinación del MOE por ultrasonido ha mostrado que es posible utilizar esta técnica en la selección y mejorar genéticamente los individuos ya que su heredabilidad es suficiente (LINDSTRÖM et. al., 2004, TAKATA and TERAOKA, 2002).

Es debido a la poca información que existe sobre la heredabilidad de la propiedades de la madera de *T. grandis* es que el presente trabajo tiene como objetivo de establecer la heredabilidad de siguientes propiedades de la madera de teca, peso específico, densidad verde, algunas parámetros del árbol (porcentaje de duramen, corteza y médula), contracciones (tangencial, radial y volumétrica), parámetros de color en el sistema CIE Lab, durabilidad con hongos de pudrición blanca y modulo de elasticidad dinámico. Así mismo se establece un agrupamiento de clones que presentan un color similar y se establece as diferencias con el color ideo para la comercialización de la madera.

METODOLOGIA

Sitio de estudio

Se realizó el estudio en dos plantaciones ubicadas en dos sitios diferentes de la zona Nor-Oeste de Costa Rica, uno ubicado en la Península de Nicoya (Sitio 1) y el otro próximo a la frontera con Nicaragua (Sitio 2). Estas plantaciones son parte de ensayos experimentales de la empresa MACORI S.A (SCHMINCKE, 2000). El sitio 1 (Garza) presenta una precipitación promedio de 1594 mm, con una temperatura media anual de 26°C y una época seca de 4 meses sin ningún tipo de precipitación. El suelo es de textura franca, acidez (pH) moderadamente ácido a neutro (6-7) y con una pendiente menor 3%. Estos suelos se caracterizan por tener fertilidad moderada y carecer de materia orgánica. En el sitio 2 las condiciones son: precipitación promedio de 1745 mm, con una temperatura media anual de 27°C y con un periodo de 5 meses sin

ningún tipo de precipitación. El suelo es de textura franca a franco-arcilloso, acidez (pH) moderadamente ácido (5-6) y con una pendiente menor 3%. Estos suelos se caracterizan por tener fertilidad moderada y carecer de materia orgánica.

Condiciones de las plantaciones y selección de los árboles.

La edad de las plantaciones fue de 10 años en el momento del muestreo, el cual que corresponde a un segundo raleo comercial. El ensayo de cada sitio originalmente consistía de 40 clones plantados en cinco bloques, dentro de los cuales se disponía de dos individuos de cada clon distribuidos aleatoriamente dentro del bloque (Figura 2), lo que significa una totalidad de 80 árboles por bloque con espaciamiento de 3 x 3 m entre árboles. El momento del estudio fue solamente posible completar el muestreo en 20 clones ya que eran los únicos que tenía todos sus individuos completos. Así mismo en dichos ensayos fue aplicado un raleo de aproximadamente 50% a la edad de 5 años, por lo que la densidad de los oscilaba entre 400-500 árboles/ha, considerando la disminución por el raleo y aquellos clones que no sobrevivieron durante los 10 años que han transcurrido. Las condiciones de los árboles muestreados son detallados en el cuadro 1.

Muestreo

Para la selección de los árboles a muestrear, de cada uno de los clones fue seleccionado 1 árbol de los 3 primeros bloques, de cada uno de los sitios, lo que significa 1 árbol x 2 sitios x 3 repeticiones (6 árboles en total). Estos árboles están libres de torceduras, sin daños por hongos e insectos. Antes de cortar los árboles fue marcada su posición norte. Posteriormente se obtuvo una troza de 100 cm de longitud a la altura del pecho (DAP) hacia abajo, así mismo fue extraído dos discos de 3 cm de grueso ubicados al DAP. En la trozas fue cortado una sección diametral de 3 cm en dirección norte - sur (Figura 1). Estas muestras fueron acondicionadas a una temperatura de 22 °C y una humedad relativa de 66%, para lograr el 12% de contenido de humedad de equilibrio. Al llegar a esta condición, fue necesario eliminar algunas muestras con presencia de nudos, pudrición u otro defecto presente con el fin de permitir el paso libre de la onda de ultrasonido.

Cuadro 1. Condiciones de los clones en el momento de realizar el muestreo.

Clon	Sitio 1 (Garza)			Sitio 2 (peñas Blancas)		
	DAP (cm)	Altura Total (m)	Altura de copa	DAP (cm)	Altura Total (m)	Altura de copa (m)
1	15.32	17.70		23.10	17.20	6.60
2	15.73	16.30		19.05	16.00	6.85
3	14.95	13.90		19.82	18.90	7.27
4	21.12	18.93		21.10	19.47	7.78
5	20.57	17.07		22.62	19.58	7.07
6	18.10	19.10		21.77	17.57	5.93
7	20.12	19.27		23.02	19.30	7.42
8	18.15	19.85		23.58	18.48	5.55
9	20.03	15.85		27.27	14.83	10.68
10	20.15	19.75		22.52	19.97	9.67
11	21.80	16.60		22.20	18.90	7.17
12	19.50	18.75		20.63	19.30	5.25
13	18.17	17.13		22.67	18.97	5.73
14	20.08	16.87		24.23	17.90	7.70
15	22.65	18.10		29.95	19.67	6.67
16	22.55	16.75		22.15	14.43	11.27
17	18.38	18.00		22.38	17.90	6.98
18	18.30	18.50		21.72	17.25	6.03
19	22.23	18.60		24.37	18.97	6.80
20	19.42	16.25		22.32	17.63	5.61

Legend: clone numbers were modified because the company considered not convenient to give publishing.



Figura 1. Diseño del bloque en el ensayo clonal y muestreo para la determinación de las propiedades de la madera.

Determinación de la velocidad de ultrasonido: Las mediciones de la velocidad de ultrasonido fue realizado en sentido longitudinal sobre las tablas de la sección diametral en cuatro distancias respecto a la médula: próximo a la medula (pith), 50% entre la distancia del radio del duramen (middle), el limite entre el duramen y la albura

(heartwood borders) y la última medición a la mitad del espesor de la albura (sapwood). Sobre cada distancia de muestro fueron medidas del tiempo que tarda la onda en pasar de un extremo a otro de la tabla en 2 ocasiones. Las pruebas se llevaron a cabo utilizando el equipo de ultrasonido SYLVATESTDUO con transductores de 22 kHz. En la configuración de este dispositivo se estableció realizar 4 lecturas por medición. Posteriormente se calculó la velocidad de ultrasonido (Ecuación 1) y luego se el calculó el módulo de elasticidad dinámico (Ecuación 2). Para la determinación de la densidad se extrajo del sitio donde se aplicó la onda de ultrasonido en el extremo de la tabla se cortó una sección de 2 cm de longitud, con el espesor y ancho de la tabla, posteriormente se determinó el peso y el volumen por desplazamiento de agua como lo indica la norma D143 (ASTM, 2003).

$$V = L \times T \quad (1)$$

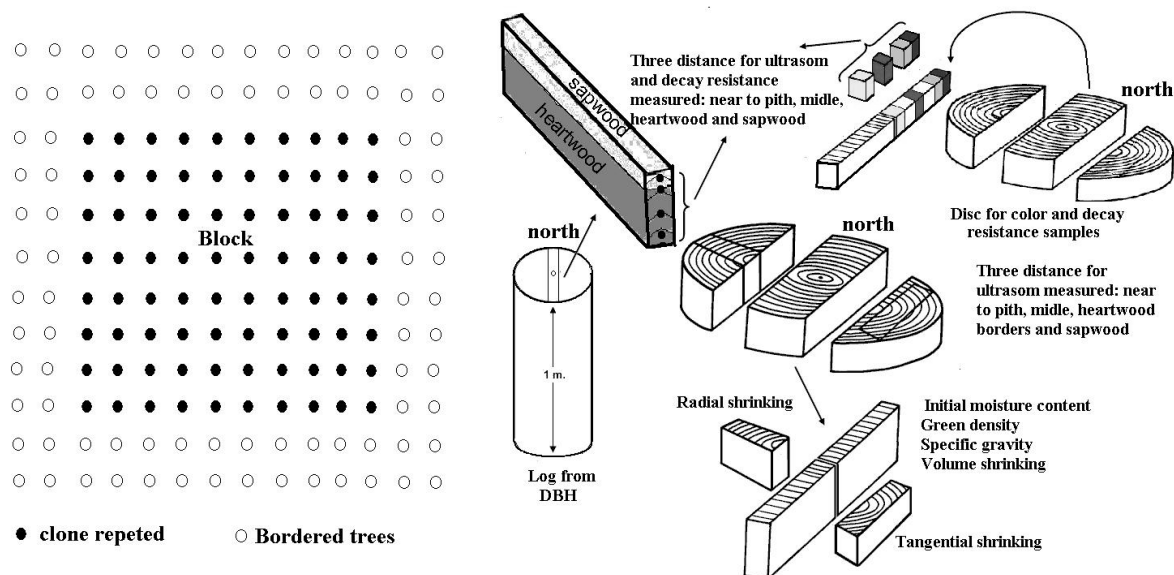
$$E_d = V^2 \times d \times 10^{-6} \quad (2)$$

Donde:

V = velocidad de ultrasonido en m s⁻¹

L = longitud de la muestra en metros

T = tiempo que tarda onda de ultrasonido de un extremo a otro de la tabla en μ s

E_d = módulo de elasticidad dinámico en GPa

D = densidad de la madera en kg/m³

Determinación de color de la madera

En la determinación del color de la madera se tomaron un disco tomado al DAP y se extrajo una sección diametral de 3 cm de ancho (Figura 1). Posteriormente se cortó un bloque de 2 x 2 x 2 cm en las mismas distancias relación a la medula que fue medido la velocidad de ultrasonido (pith, midle, heartwood borders and sapwood). Un total de 960 muestras (8 muestras por disco x 3 repeticiones x 20 clones x 2 sitios) fueron extraídos de los árboles muestreados. El color de la madera fue medido en una cara tangencial del bloque siguiendo la norma ISO 7724/1-1984 y ISO 7724/2-1984. Fue utilizado el espectrofotómetro marca miniSkan XE Plus de HunterLab. Las mediciones se realizaron a temperatura ambiente y los datos de color se uso el sistema cromatológico estandarizado CIELAB, Iso cuales se tiene 3 parámetros L*, *a*b*. El rango de esta medida es de 400 a 700 nm, con una apertura en el punto de medición de 13 mm. Para la observación de la reflexión fue incluido el componente especular (SCI mode), en un ángulo de 10° la cual es lo normal de la superficie del espécimen

(D65/10); un campo de visión de 2° (Observador estándar, CIE 1931) y un estándar de iluminación D65 (Correspondiente a Luz del día en 6500 K).

Durabilidad de la madera

Una vez medido el color de la madera, las muestras se sometieron a un ensayo acelerado de ataque de *Trametes versicolor* (L.) Pil. y *Pycnoporus sanguineus* (L.) Merrill, ambos reconocidos como de pudrición blanca agresiva en especies de maderas latifoliadas (KOKUTSE, et al., 2006). En este ensayo siguió la norma D-2017-81 (ASTM 2003a), en donde la relativa resistencia de la madera se mide como el porcentaje de pérdida de peso durante una exposición durante 12 semanas tanto para la madera de albura y duramen, por lo que en esta parte fueron determinadas 4 características: pérdida de peso del duramen ante *Trametes versicolor* (TV-HRW) y este tipo de madera ante *Pycnoporus sanguineus* (PS-HRW) y en la pérdida de peso del albura ante los hongos de producción blanca *Trametes versicolor* y *Pycnoporus sanguineus*, codificado como TV-SAP y PS-SAP, respectivamente.

Determinación de propiedades físicas de la madera

Se realizó el análisis de otras propiedades físicas de la madera utilizando el otro disco obtenido al DAP. Las siguientes propiedades físicas fueron determinadas: contracción radial (RS), tangencial (TS) y volumétrica total (VS), densidad en condición verde (GD), contenido de humedad inicial (IMC) y el gravedad específica (GS). En la obtención de las muestras fue utilizado el patrón mostrado en figure 2. El peso y el volumen de las dos submuestras diametral fueron determinados en condición verde acorde D-2395-02 (ASTM, 2003b) y posteriormente las muestras fueron secadas en horno a 105 °C por 24 hrs para determinar nuevamente su peso y volumen con la misma norma D-2395-02. Los valores de peso y volumen verde y seco al horno fue utilizado para calcular GD, VS, IMC y GS. La TS y RS fueron determinadas y calculados acorde con D-2395-02.

Análisis estadístico

A excepción del porcentaje de duramen, medula y corteza y las contracciones radiales y tangenciales que fue obtenido un solo valor por árbol muestreado, el resto de las propiedades de la madera fueron obtenidos dos (IMC, GD, SG) o cuatro (parámetros de color, modulo de elasticidad dinámico, y perdida de peso con los hongos) valores por árbol, dichos valores fueron promediados para cada uno de los árboles muestreados, obteniendo por tanto un solo valor por árbol. Then, before analysis of variance or others analysis was necessary to satisfy its assumptions, mainly normal

distribution and homogeneity of variance. Data transformations were necessary wood properties. Logarithmic transformations were applied in pith percentage, volumetric, tangential and radial shrinking, radio tangential/radial, a* and weight loss of heartwood with *Trametes versicolor*. For green density was required to transform with X^2 , for specific gravity with its inverse ($1/X$), for dynamic compression module elasticity with square root and some weight loss with *Pycnoporus sanguineus* of sapwood with $X^{1.5}$. The UNIVARIATE procedure of SAS System for Windows release 8.1 (SAS Institute Inc., Cary, N.C.) was used to analyze assumptions of analysis of variance.

The equation 3 shows mixed linear model was used in the univariate analysis of wood properties. The model included the following sources of variation: clone (c), site (s), the interactions between clone and site and block within site.

$$Y_{ijk} = \mu + c_i + s_j + c * s_{ij} + s(b)_{jk} + e_{ijk} \quad (3)$$

Where Y_{ijk} is an observation of each wood properties of the ijk th tree, μ is the overall mean, c is clone random effects i th, s is site fixed effects j th, $c*s_{ij}$ is the random interactions between the i th clone and the j th site and $s(b)_{jk}$ is the random effect of k th block within j th site, and e_{ijk} is the residual random effect. The GLM produce of SAS (SAS Institute Inc. 2001) was applied to estimate the significance of sources of variation.

Estimates of variance components was made using VARCOMP produce with the restricted maximum likelihood method of SAS. It was performed the mixed linear model described (3). Narrow-sense heritability was estimated for wood parameters and was performed the following equation:

$$h^2 = \frac{2\sigma_c^2}{2\sigma_c^2 + \sigma_s^2 + \sigma_{c*s}^2} \quad (4)$$

Where σ_c , σ_s and σ_{c*s} are respectively the variance among clone, site and interactions between clones and site. Phenotypic (Pearson correlation matrix) and genetic correlations were estimated for wood properties. The first one was calculated by CORR procedure and included both genetic and environmental effects. The trait values were standardized for calculation genetic correlation.

RESULTADOS

Mean and variation of wood properties

Los valores promedio de las propiedades de madera que fueron evaluados son presentados en el cuadro 2. En él es posible observar que los mayores CV ocurren en la pérdida de peso de duramen para los dos tipos de hongos (PV-HRW and PS-HRW). Para estas dos características de la madera se tiene que los valores variaron de 1.29% hasta 50.14% en TV-HRW y de seguido 1.21 a 26.20% en PS-HRW. Posteriormente la propiedad de la madera con mayor variación es PP, que presenta una variación de alrededor de 63%. Por otro lado, también se observa que los menores valores en el CV ocurren en los parámetros de color (L^* , a^* and b^*), la SG y GD, con valores de menor a 11%. Un grupo de propiedades de la madera (E_d , shrinkring of wood, HWP, and BC) presentan CV que oscilan entre 10 y 30%. Así mismo, pérdida de peso ante el ataque de hongos de pudrición blanca del albura (TV-SAP and PS-SAP) presentan variaciones entre 40 and 50% (Table 2)

Table 2. Descriptive statistics of some wood properties for different clones of *Tectona grandis* growing in Costa Rica. (N=110).

Wood properties	Mean	CV	Range
HWP	38.33 (7.46)	19.47	38.79
BP	19.16 (4.78)	24.97	19.01
PP	0.16 (0.10)	62.73	0.48
IMC	104.35 (24.36)	23.35	112.87
GD (g/cm ³)	1.01 (0.11)	10.44	0.43
SG	0.50 (0.04)	8.01	0.20
VS (%)	7.23 (1.37)	18.95	8.07
TS (%)	4.16 (0.81)	19.35	3.51
RS (%)	2.74 (0.82)	29.76	3.25
Ratio T/R	1.53 (0.29)	19.05	1.15
L^*	62.68 (3.58)	5.71	20.77
a^*	9.47 (1.01)	10.61	4.65
b^*	28.63 (1.87)	6.52	10.16
E_d (GPa)	12.81 (1.76)	13.72	7.30
TV-HRW (%)	16.94 (12.43)	73.38	51.23
PS-HRW (%)	7.26 (4.27)	70.75	25.60
TV-SAP (%)	30.54 (12.57)	41.15	48.80
PS-SAP (%)	15.13 (7.76)	51.28	42.68

Legend: HWP=heartwood percentage, BP= bark percentage, PP=pith percentage, IMC= initial moisture content, SG= Specific gravity, VS= Volume shrinking, TS= Tangential shrinking, RS= Radial shrinking, Ratio T/R= Relation tangential and radial shrinking, E_d = Dynamic compression module elasticity, TV-HRW= weight loss with *Trametes versicolor* fungi in heartwood, PS-HRW= weight loss with *Pycnoporus sanguineus* fungi in heartwood, TV-SAP= weight loss with *Trametes versicolor* fungi in sapwood, PS-SAP= weight loss with *Pycnoporus sanguineus* fungi in sapwood.

Los valores obtenidos en los parámetros relacionados al árbol (HWC, BP and PP) se encuentran dentro de los rango establecidos para esta especie creciendo en condiciones de plantación es de rápido crecimiento. Por ejemplo, los valores encontrados para HWP and BP (38.33% and 19.16% respectively) están dentro del rango establecido por PÉREZ and KANNINEN (2005), quienes reportan para árboles de teca de plantaciones entre 7 y 45 años un rango entre 0,4 a 61% en HWC duramen y para la corteza de 14 y 37%. En tanto, que MOYA and PÉREZ (2008) en árboles entre 7 a 15 años de plantaciones de rápido crecimiento, RIVERO and MOYA (2006) and BHAT (1995), para árboles de 8 años, también en condiciones de rápido crecimiento reportan valores de 10-60%, 27.89% y 30% respectivamente, valores similares los encontrados en el presente trabajo.

El valor de propiedades físicas como GD, SG, and shrinking (VS, TS and RS) nuevamente están dentro del rango de valores encontrados en otros estudios como MOYA (2002), MOYA and ARCE (2003, 2006), MOYA et al. (2003) and MOYA and PÉREZ (2008) también de madera provenientes de árboles de plantaciones de rápido crecimiento en Costa Rica con edades de 4 a 15 años. Señalando los diferentes autores que estos valores en la propiedad de la madera de teca presentan una relación el diámetro, altura, manejo de las plantaciones, condiciones ambientales, así como las características físicas y químicas del suelo. Por otro lado, RIVERO and MOYA (2006), en la tabla 4 hacen una amplia revisión de algunas propiedades físicas (SG, IMC and different shrinking), observando en él que los valores presentados son congruentes con los valores encontrado en el presente trabajo.

En lo relacionado a los parámetros del color, se tiene que MOYA and BERROCAL (2009) establecen la variación de los parámetros de colores (L^* , a^* and b^*) también para árboles de plantaciones de rápido crecimiento en Costa Rica. Ellos reportan para L^* ranged from 63.6 to 80.9 in sapwood and from 46.8 to 70.6 in heartwood, the a^* ranged from 1.9 to 11.7 and 5.1 to 13.6 for sapwood and heartwood, respectively; and b^* from 19.4 to 32.6 for sapwood and from 4.1 to 29.5 in heartwood. Siendo los valores encontrado para los clones similares a los encontrado en nuestro estudio.

En la pérdida de peso por ataque de hongos blanca, se tiene, además de la alta variación entre los datos, que los valores promedios encontrados son congruente con los reportados por MOYA et al. (2009) para árboles de 14 años de edad en plantaciones de rápido crecimiento. Dichos autores también encontraron también una cantidad importante de muestras de duramen principalmente se presentaban valores

de pérdida de peso similar a los obtenidos a la madera de albura y con grandes variaciones de los datos, muy similar a nuestro caso que se presentaron valores de pérdida de peso en duramen desde 1.29% hasta 50.14%. Dichos autores, basados en las afirmaciones de BHAT y FLORENCE (2003), suponen que la alta susceptibilidad de los árboles en algunas regiones a producir más duramen se debe a que en esas partes poseen muy bajo contenidos de extractivos en la madera. Otros estudios sobre la resistencia al ataque de hongos (BHAT et al. 2005; KOSUTSE et al. 2006; LUKMANDARU and TAKAHASHI 2008), también muestran valores similares a los encontrados en el presente estudio, sin embargo estos estudios relacionan estas pérdidas de peso con los componentes del color medidos con CIELAB.

Analyses of variance, variance components and heritability

Results of the analyses of variance are presented in Table 3 for different wood properties in *T. grandis* clones. Significant differences between the two sites were observed for all wood properties, except for HWP, which not significant were found. The variance percentage due to site ranged from 1.37 to 75.87% (Table 3). The highest values of variance occurred for TV-SAP, RS and TV-HRW and it varied over 50%. For PS-SAP, GD, TS and IMC, the total variance was explicated from 40 to 50% for site. The minor values (from 14 to 33%) were found for PS-HRW, ratio R/T, BP, a* and b*. The lowest values of variance explained for site were presented in VS, Ed, SG, PP and L*. Finally, the variance of HWP was not explained for site (Table 3).

The ANOVA analysis showed that clone was statistically significant BP, PP, IMC, GD, SG, different shrinking, wood color parameters and Ed. Not significant effects were found in HWP, Ratio T/R and weight loss with two white fungi (Table 3). The coordinates L* of wood color was wood properties with the highest values of variance explained for clone, with 53.38%, Subsequently, PP, SV, SG, Ed, a* and b* the variance percentage varied from 20.00 to 46.26%. Variance from 6.6 form 21.4% was established in BP, SR, ST and IMC. The lowest values of variance explained for clone, as expected, was found where not significant effect of clone was found, in HWP, Ratio T/R, TV-HRW, PS-HRW, TV-SAP, PS-SAP and HWP. Besides, GD presented too the lowest values (Table 3).

The interactions between site and clone were significant in HWP, GD, SG, VS, TS and Ed, with variance percentage from 10.19 to 30.92%. Not significant effects were determined in rest of wood properties. The site (block) effects were not significant fro

any wood properties and therefore the values of variance percentage were lower than 3.41% (Table 3). Finally, the variances due to error were over 50% in BP, PS-SAP, PP, HWP, Ratio T/R and PS-HRW. The variance percentage varied from 21.96 to 47.38 in others wood properties (Table 3).

Narrow-sense heretability ranged from 0 to 0.978 (Table 4) The largest h^2 estimate, over 0.90%, were 0.978 for PP, 0.90 for L*. SG, VS, Ed, a* and b* color coordinates were moderately high estimate of heretabilities, from 0.706 to 0.836. Moderate values of h^2 were found for BP, TS and IMC, from 0.438 to 0.463. Low values were estimate for GD, RS and ratio T/R, from 0.148-0.169) and finally negligible values were found for HWP and decay resistance of sap and heartwood, values almost to zero (Table 4)

Table 3. Results of analysis of variance of clone trees of *Tectona grandis* growing in two different sites in Costa Rica. (N=110).

Wood properties	Site effect (d.f.=1)		Clone effect (d.f.=19)		Clone x site effect (d.f.=1)		Site (block) (d.f.=4)		Error (d.f.=66)	
	Valor F	% VAR	Valor F	% VAR	Valor F	% VAR	Valor F	% VAR	MS	% VAR
DBH	3.68 ^{ns}	1.03	3.90 ^{**}	30.00	1.13 ^{ns}	5.21	0.65 ^{ns}	0.00	5.93	63.76
HWP	3.47 ^{ns}	0.00	3.34 ^{ns}	0.00	2.02 [*]	30.92	0.70 ^{ns}	0.00	39.16	69.08
BP	65.46 ^{**}	32.51	2.28 ^{**}	12.85	0.92 ^{ns}	0.00	1.33 ^{ns}	0.89	12.61	53.76
PP (Log10)	4.86 [*]	1.37	3.77 ^{**}	30.52	1.07 ^{ns}	0.00	1.57 ^{ns}	2.54	0.048	65.57
IMC	166.4 ^{**}	48.06	4.90 ^{**}	20.92	0.97 ^{ns}	0.41	1.13 ^{ns}	0.47	185.67	30.14
GD (x ²)	142.3 ^{**}	43.61	2.92 ^{**}	4.99	2.07 [*]	13.72	2.60 ^{ns}	3.41	0.014	34.29
SG (1/x)	7.53 ^{**}	1.52	9.46 ^{**}	45.26	2.27 ^{**}	17.36	0.80 ^{ns}	0.00	0.009	35.86
VS (Log10)	10.43 ^{**}	4.61	7.63 ^{**}	42.72	1.84 [*]	12.17	0.83 ^{ns}	0.00	0.003	40.51
TS (Log10)	216.5 ^{**}	44.68	7.24 ^{**}	21.40	2.28 ^{**}	10.19	1.73 ^{ns}	1.31	0.002	22.42
RS (Log10)	235.2 ^{**}	62.33	2.45 ^{**}	6.61	1.24 ^{ns}	2.61	0.41 ^{ns}	0.00	0.005	28.45
Ratio T/R	28.21 ^{**}	19.76	1.08 ^{ns}	1.99	0.84 ^{ns}	0.00	0.71 ^{ns}	0.00	0.030	78.25
L*	10.53 ^{**}	3.56	10.54 ^{**}	53.38	1.53 ^{ns}	7.71	0.75 ^{ns}	0.00	4.524	35.34
a* (Log10)	46.75 ^{**}	19.44	5.43 ^{**}	31.17	1.33 ^{ns}	6.50	0.31 ^{ns}	0.00	0.005	42.89
b*	76.33 ^{**}	24.22	8.66 ^{**}	43.05	1.04 ^{ns}	1.66	0.40 ^{ns}	0.00	1.157	31.07
Ed (\sqrt{x})	24.25 ^{**}	2.95	17.08 ^{**}	46.26	4.44 ^{**}	28.83	0.83 ^{ns}	0.00	0.133	21.96
TV-HRW	323.9 ^{**}	75.87	1.21 ^{ns}	1.32	0.54 ^{ns}	0.00	0.30 ^{ns}	0.00	39.69	22.81
PS-HRW (Log10)	22.14 ^{**}	14.09	0.92 ^{ns}	0.00	1.42 ^{ns}	5.32	1.61 ^{ns}	1.89	0.076	78.71
TV-SAP (x ^{1.5})	114.0 ^{**}	50.35	1.18 ^{ns}	2.28	0.98 ^{ns}	0.00	0.45 ^{ns}	0.00	241690	47.38
PS-SAP	73.99 ^{**}	40.33	0.82 ^{ns}	0.00	1.12 ^{ns}	1.92	0.42 ^{ns}	0.00	36.77	57.75

Legend: HWP=heartwood percentage, BP= bark percentage, PP=pith percentage, IMC= initial moisture content, SG: specific gravity, VS= Volume shrinking, TS= Tangential shrinking, RS= Radial shrinking, Ratio T/R=relation tangential and radial shrinking, Ed= dynamic compression module elasticity, TV-HRW= weight loss with *Trametes versicolor* fungi in heartwood, PS-HRW= weight loss with *Pycnoporus sanguineus* fungi in heartwood, TV-SAP= weight loss with *Trametes versicolor* fungi in sapwood, PS-SAP= weight loss with *Pycnoporus sanguineus* fungi in sapwood.

Como los mismos clones fueron seleccionados en los dos sitios, da como resultado que la misma constitución genética del material es similar para ambos sitios dos sitios. Así, el efecto significativo del sitio en todos las propiedades de la madera, excepto el HRW, indica que los efectos ambientales o del sitio afectan la constitución anatómica o física de la madera. There are many literatures that reported of effect of site on wood properties (SARANPÄÄ, 2003; ZOBEL and VAN BUIJTEJEM, 1998). However, it difficult to separate environmental conditions and soil properties (ZOBEL and JETT, 1995). Los dos sitios donde fueron establecidos los ensayos clones presentan algunas diferencias en las condiciones climáticas y de fertilidad de suelo, en el caso del sitio 1, la precipitación media existe una diferencias entre los sitios de alrededor de 200 mm al año, diferencias en temperatura de apenas 1 °C y uno de ello, posee en un mes más en el periodo seco tiene un periodo seco, además de algunas diferencias que se presentan en el tipo de suelo y la acidez del mismo. Although, it was found difference on wood properties among sites, it difficult to established si estas diferencias se producen por

las condiciones del suelo o las condiciones ambientales anteriormente descritas, ya que no fue estudiado estos factores no fueron considerados en presente estudio. Recientemente, MOYA and PÉREZ (2008) have shown that certain soil characteristics, such as the content of calcium, copper, and phosphorus, as well as the sand and silt percentages, were correlated with many physical wood properties of *Tectona grandis* growing in fast-growth plantations. Aunque el estudio de clones en especies tropicales poco conocido, a excepción de los eucaliptos (GAVA and MORAIS, 2008; MIRANDA et al., 2007; VANCLAY et al, 2008), en algunas otras especies de menor importancia también se ha encontrado que el sitio afecta en clones. Por ejemplo, *Dalbergia sissoo* (PANDE and SINGH, 2005) el sitio fue significativo en los ensayos clonales estudiando la densidad básica y alguna características anatómicas, no obstante otra especie tropical los datos fueron contradictorios, en *Calycophyllum spruceanum* (SOTELA et al., 2007) no se encontró efecto del sitio en el ensayo clonal cuando se estudio las densidad y algunas propiedades mecánicas. Así, el resultado encontrado que el sitio tiene efecto en las propiedades de la madera en *T. grandis* es posible lograr aun más ganancia en algunas propiedades de la madera, aparte de la propiedad del clon como por una mejor selección de los sitios para plantar estos árboles

Algunas propiedades de la madera con importante influencia en los procesos industriales como en el secado (relacionado con las IMC y las contracciones), la resistencia mecánica (relacionado con el SG y E_d), el color de madera (influenciado por L^* , a^* , b^*) mostraron que existe diferencias entre los diferentes clones analizados (Table 3). Dichos resultados y la heredabilidad que presenta estas características (Table 3) permiten sugerir que algunas clones pueden ser seleccionados en los programas de reforestación comercial con el fin de tener las mejores calidades de madera para estas condiciones de procesos. Sin embargo, es conveniente también que se considere otros aspectos relacionados al crecimiento y producción en las plantaciones (ZOBEL and JETT, 1995).

Así mismo, aunque los estudios sobre la heredabilidad en las características morfológicas de los árboles son abundantes en teca (CALLISTER and COLLINS, 2008; GOH and MONTEUUIS, 2005), los estudios sobre la variación entre clones son escasos y limitados a pocas propiedades, focalizados en la SG and el HWP (BHAT and INDIRA, 2005; INDIRA and BHAT, 1997; RAO and SHASHIKALA, 2003) y demuestran que demuestran que la inter variación entre clones o la heredabilidad esta presente, como fue encontrado en este estudio para una amplia propiedades de la madera. BHAT and INDIRA (2005) encontraron que la densidad, junto con otros características

anatómicas de la madera de teca, que en el caso de SG la variación esta presente entre clones, pero con baja heredabilidad, siendo este resultado diferente al obtenido en presente estudio. Entre tanto INDIRA and BHAT (1997) y RAO and SHASHIKALA (2003) también encontraron variabilidad entre clones, y baja heredabilidad para la densidad. Otras especies tropicales o semitropicales, concuerdan con lo encontrado en el presente trabajo, por ejemplo en *Calycophyllum spruceanum* (SOTELA et al., 2008) encontró efecto del clon y la heredabilidad en las propiedades mecánicas de madera. En *Eucalyptus dunnii* fue encontrado un moderado valor de heredabilidad de los parámetros del color. En *Dalbergia sissoo* (PANDE and SINGH, 2005) mostró que SG, el clon es significativo y presenta una heredabilidad moderada.

Por otro lado fue encontrado que una característica importante para la madera de teca, el HWP, que no fue afectado por el clon y por tanto no presenta un coeficiente de heredabilidad significativo (Table 3). Dicho resultado difiere de lo reportado por MODAL and CHAWHAAN (2003) y RAO and SHASHIKALA (2003) mostraron la heredabilidad del HWP y la control genético por clones en teca, diferente al encontrado en el presente estudio. No obstante en estos trabajos es importante resaltar que por un lado se utilizó progeny trial de 20 años edad (MODAL and CHAWHAAN, 2003) y en el otro caso fueron utilizados poca individuos por clon para determinar la heredabilidad en edades de 16 años (RAO and SHASHIKALA (2003). Además de en ambos trabajos no fue considerado varios sitios, si no que fue utilizado solamente una sitio. Dichos resultados muestran que la cantidad de duramen presentes en el árbol, no solamente esta influenciado por el clon, si no que probablemente otros aspectos están influenciado por otros aspectos que pueden ser propios del árbol o en las condiciones de crecimiento que esta sometido el árbol que permite el desarrollo del diámetro como el manejo de las plantaciones. Importantes estudios han mostrados que el desarrollo del duramen tiene relación con el manejo de la plantación (KANNINEN et al., 2004; PÉREZ and KANNINEN, 2003, 2005; VÍQUEZ and PÉREZ, 2006) y que algunas condiciones del árbol como el desarrollo de la copa tiene relación directa con el desarrollo del área de albura (MORATAYA et al., 1999) y por tanto afectando el área de duramen.

El duramen, componente más importante para la venta de madera, con los resultados obtenidos no indica que el controlar genético es moderadamente difícil de realizar ya que presente diferencia entre clones pero es poco heredable. No obstante, una forma de manejar esta propiedad de la madera con clones de teca es a través del desarrollo del diámetro del árbol y el manejo de las plantaciones. En el presente estudio con clones se ha encontrado que HWP presenta correlación con el DBH (Figure 2) y que

por tanto los clones con mejor desempeño en diámetro se va a tener indirectamente una buena producción en duramen. El DBH se encontró que además de que es influenciado por el clon (Table 2) y su índice de heredabilidad es bastante alto (Table 3). La heredabilidad del DBH es concordante con los presentados por otros estudios, que han mostrado que DBH presenta una moderada o alta herebilidad, además puede tener una ganancia genética, cuando se ha evaluado trial de edades tempranas (menor a 8 años). Por ejemplo, algunos autores han encontrado que la heredabilidad del diámetro puede oscilar 0.22 to 0.71 para clones de teca en edades tempranas (CALLISTER and COLLINS, 2008; SHARMA et al., 2000). Entre tanto otros estudios muestran que la heredabilidad en el diámetro del carbol es superior a 0.70 (HARSHAP and SOERIANEGARA, 1977; MURILLO and BADILLA, 2004). Así mismo, un manejo que estimule el desarrollo en diámetro de las plantaciones clonales trae consigo un incremento en el HWP (KANNINEN et al., 2004; PÉREZ and KANNINEN, 2003, 2005; VÍQUEZ and PÉREZ, 2006).

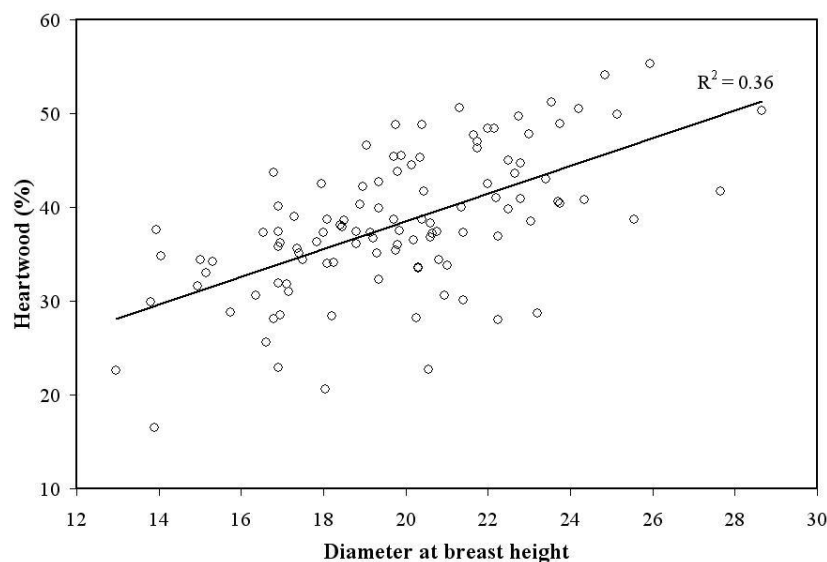

Figure 2, Relationships between heartwood percentage and diameter at breast height parameters for twenty clones of *Tectona grandis* growing in plantation in Costa Rica.

Table 4. Descriptive statistics of some wood properties for different clones of *Tectona grandis* growing in Costa Rica (N=110).

Wood properties	h ² _g	Phenotypic correlation (Pearson correlation coefficient)			
		Genetic correlation		Genetic correlation	
		Clon	Site	Clon	Site
DBH	0,906 ± 0,0005 ±				
HRW	0,0655			5,029	17,132
Bark	0,441 ± 0,1175			10,591	21,390
Pith (Log10)	0,978 ± 0,1636			38,010	49,200
IMC	0,463 ± 0,1686			10,805	13,243
GD (x ²)	0,148 ± 0,0819 0,827 +-			2,342	6,127
SG (1/x)	0,1866			5,695	5,285
VS (Log10)	0,836 ± 0,1722			12,121	12,446
TS (Log10)	0,438 ± 0,1530			9,660	11,956
RS (Log10)	0,169 ± 0,0136			3,281	64,339
Radio T/R (Log10)	0,168 ±				
L*	0,905 ±				
a* (Log10)	0,706 ±				
b*	0,769 ±				
Ed (√x)	0,744 ±				
TV-HRW	0,034 ±				
PS-HRW (Log10)	0,000 ±				
TV-SAP (x ^{1.5})	0,083 ±				
PS-SAP	0,000 ±				

Legend: see table 3

Table 5. Phenotypic correlation (Pearson coefficient) of wood properties of different clone of *Tectona grandis* (N=100).

	DBH	HRW	Bark	Pith	IMC	GD	SG	VS	TS	RS	Ratio T/R	L*	a*	b*	Ed	TV-HRW	PS-HRW	TV-SAP	PS-SAP
DBH	1,00																		
HRW	0,57**	1,00																	
Bark	-0,26**	-0,28**	1,00																
Pith	-0,45**			1,00															
IMC			0,51**		1,00														
GD			0,60**	-0,31**	0,75**	1,00													
SG					-0,49**		1,00												
VS								1,00											
TS			0,45**		0,37**	0,44**		0,50**	1,00										
RS			0,45**		0,39**	0,46**		0,43**	0,69**	1,00									
Ratio T/R					-0,28**	-0,33**				-0,58**	1,00								
L*												1,00							
a*			0,34**		0,42**	0,46**				0,31**		-0,65**	1,00						
b*		0,25**	0,23**		0,51**	0,33**	-0,31**		0,25**	0,29**			0,35**	1,00					
Ed	-0,28**	-0,37**			-0,37**		0,36**	0,34**						-0,29**	1,00				
TV-HRW			-0,45**		-0,48**	-0,53**			-0,57**	-0,69**	0,33**	0,31**	-0,45**	-0,44**		1,00			
PS-HRW					0,25**				0,29**	0,26**				0,29**			1,00		
TV-SAP	-0,26**		-0,35**		-0,45**	-0,48**			-0,53**	-0,50**			-0,38**	-0,34**		0,65**		1,00	
PS-SAP			0,29**		0,51**	0,42**			0,44**	0,47**			0,28**	0,29**	-0,25**	-0,54**	0,27**	-0,53**	1,00

Legend: see table 3

Conclusion

This study shown that *Tectona grandis* clones presents same quality concerns, it appears with adequate SG, shrinking and stiffness. The wood color is similar to others wood from fast-growth trees. And it also established that variation in wood properties is due to genotypic effect in PP, L*. SG, VS, Ed, a* and b* BP, TS and IMC and Narrow-sense heretability were with moderate to high values in these wood properties. But low heritabilities were estimate for GD, RS and ratio T/R and negligible values were found for HWP and decay resistance of sap and heartwood. The phenotypic, environmental and site conditions have a strong effect of these properties.

Special results found for HWP, because it is an important wood characteristics for wood merchantable. It was estimate that variation is present between clones but negligible heritability were found. Heartwood formation may be genetically influenced not only by being strongly inherited, but possibly also genetically influenced by others characteristics of tree and it were not studied in this study. However, we can increase heartwood productions with management of plantation, stimulating diameter growth of tree. It is important to establish the relationships of heartwood and tree characteristics and so, we can understand heartwood formation in clonal trees.

Phenologycal and genologycal correlations indicate that tree selecting clone with faster growth will be increase others important wood characteristics in *Tectona grandis*, as heartwood proportions, tree with lower pith and bark content. However, others characteristics to evaluate is necessary to evaluated with improving clone with faster growth. It presents negative correlations with mechanical wood resistance and decay resistance of sapwood. On the other hand, selecting clone with denser wood, as expect, improve Ed, different shrinking, wood color and decay resistance were not affect. Finally, wood with highest values of b* wood color coordinates increased decay resistance of *Trametes versicolor*, but increases *Pycnoporus sanguineus* fungi attack.

Acknowledgements

The authors wish to thank The Research Vice-Rectory of the Technological Institute of Costa Rica (ITCR), and Precious Woods of Central America (MACORI) for supplying the clone for this experiment, mainly to Ing. Ronald Guerrero and Ing. Adrian Delgado.

References

- ASTM (2003a): Standard method of accelerated laboratory test of natural decay resistance of woods. ASTM D 2017-81. Annual Book of ASTM Standards, Vol. 04.10. Philadelphia. USA.
- ASTM (2003b): Standard test methods for specific gravity of wood and wood-base materials. ASTM D 2395-02. Annual Book of ASTM Standards, Vol. 04.10. Philadelphia. USA.
- BHAT, KM. (1995): A note on heartwood proportion and wood density of 8-year-old teak. *Indian Forester* 121(6): 514-517.
- BHAT, K.M. and E.J. FLORENCE (2003): Natural decay resistance of juvenile teak wood grown in high input plantations. *Holzforschung* 57: 453-455.
- BHAT, K.M. and E.P. INDIRA (2005): Genetic gains in wood quality attributes of clonal teak (*Tectona grandis* L.f.). *J. Timber Dev. Assoc of India* 51(1/2): 30-36.
- KHAT K.M., P.K. THULASIDAS and F.J FLORENCE (2005): Wood durability of home-garden teak against brown-rot and white-rot fungi. *Tree* 9: 654-660.
- CALLISTER, A.N. and S.L. COLLINS (2008): Genetic parameter estimates in a clonally replicated progeny test of teak (*Tectona grandis* Linn. F). *Tree Genet Genom* (2008) 4: 237-245.
- CILAS, C., C. GODIN, B. BERTRAND and H. BAILLÈRES (2006): Genetic study on the physical properties of *Coffea arabica* L. wood. *Trees* 20: 587-592.
- FAO (2006): Global planted forest thematic study: results and analysis. Working paper 38. Rome.
- GAVA, J.L., J.L. MORAES (2008): Soil attributes and wood quality for pulp production in plantations of *Eucalyptus grandis* clone. *Sci Agric* 65: 306-313.
- GOH, D.K.S and O. MONTEUUIS (2005): Rationale for developing intensive teak clonal plantations, with special reference to Sabah. *Bois et Forêt des Trop* 285: 5-16.
- HANNRUP B., C. CHRISTINE, G. GUILLAUME, M. GRABNER, B. KARLSSON, I. LE BAYON, J. LLOYD, U. MÜLLER, H. PEREIRA, J.C. RODRIGUES, S. ROSNER, P. ROZENBERG, L. WILHELMSSON and R. WIMMER (2004): Genetic parameters of growth and wood quality traits in *Picea abies*. *Scand J Forest Res* 19: 14-29.
- HARSHAP, R.M.S, I. SOERIANEGARA, I (1977): Heritability of some characters in teak (*Tectona grandis* L.f.), pp 649–657 in *Third World Consultation on Forest Tree Breeding, Volume 2*. CSIRO, Canberra, Australia.
- INDIRA, E.P. and K.M. BHAT (1997): Variability and heritability of wood density in teak (*Tectona grandis* L.f.). *J. Trop Forestry* 13(1): 1-5.
- MOSEDALE, J.R., B. CHARRIER and G. JANIN (1996): Genetic control of wood colour, density and heartwood ellagitannin concentration in European oak (*Quercus petraea* and *Q. robur*). *Forestry* 69: 111-124
- KJÆR, E.D., H.R. SIEGISMUND and V. SUANGTHO (1996): A multivariate study on genetic variation in teak (*Tectona grandis* (L.)). *Silvae genetica* 45: 361-368.
- KJÆR, E.D., S. KAJORNSRICHON and E.B. LAURIDSEN (1999): Heartwood, calcium and silica content in five provenances of teak (*Tectona grandis*). *Silvae Genetica* 48(1): 1-3.

- KANNINEN, M., D. PÉREZ, M. MONTERO and E. VÍQUEZ (2004): Intensity and timing of the first thinning of *Tectona grandis* plantations in Costa Rica: results of a thinning trial. *Forest Ecol Manag* 203: 89-99.
- KOKUTSE, A.D., A. STOKES, H. BAILLÈRES, K. KOKOU and C. BAUDASSE (2006): Decay resistance of Togolese teak (*Tectona grandis*) heartwood and relationship with colour. *Trees* 20: 219-223.
- LUKMANDARU, G. and K. TAKAHASHI (2008): Variation in the natural termite resistance of teak (*Tectona grandis* L. f.) wood as a function of tree age. *Ann Forest Sci* 65: 708-710.
- LINDSTRÖM H., P. HARRIS, C.T. SORENSSON and R. EVANS (2004): Stiffness and wood variation of 3-year old *Pinus radiata* clones *Wood Sci Technol* (2004) 38: 579–597.
- MAZET, J.F. and G. JANIN (1990): La qualité de l'aspect des placages de Chênes (*Quercus petraea* and *Quercus robur*): mesures de couleur et critères de d'appréciation des professionnels français et italiens. *Ann. For. Sci.* 47(3): 255-268.
- MIRANDA, I., J. GOMINHO, A., LOURENCO and H. PEREIRA (2007): Heartwood, extractives and pulp yield of three *Eucalyptus globulus* clones grown in two sites. *Appita J* 60: 485-488.
- MODAL, AK and P.H. CHAWHAAN (2003): Investigation of inherence of growth and wood properties and their interrelationship in teak, pp. 434-439 in *Proceeding of International Conference Quality Timber Products of teak from sustainable Forest Management*, edited by KERALA FOREST RESEARCH INSTITUTE.. Papers for oral presentation. 2-5 December 2003. Peechi, India
- MONTEUUIS, O. and GOH, D.K.S (1999): About the use of clones in teak. *Bois Forêts Trop* 261(3):28-37
- MONTEUUIS, O. and H. MAÎTRE (2006): Los últimos avances realizados en la clonación de teca permiten mejorar la calidad del material de plantación. *OIMT Actualidad Forestal Tropical*.
- MORATAYA, R., G. GALLOWAY, F. BERNINGER and M. KANNINEN (1999): Foliage biomass – sapwood (area and volume) relationships of *Tectona grandis* L.F. and *Gmelina arborea* Roxb.: silvicultural implications. *Forest Ecol Manag* 113: 231-239.
- MOYA, R. (2002): Influencia de la edad del cambium, tasa de crecimiento y nivel de precipitación sobre la densidad básica de la teca en Costa Rica. *Maderas y Bosques* 8(1): 39-49.
- MOYA, R. and V. ARCE (2003): Efecto del espaciamiento en plantación sobre dos propiedades físicas de madera de teca a lo largo del fuste. *Maderas y Bosques* 9(2): 15-27.
- MOYA, R. and V. ARCE (2006): Estudio del efecto del espaciamiento sobre el peso específico básico y contracciones en plantaciones de teca. *Kurú: Revista Forestal* 3(7): 1-11.
- MOYA, R. and A. BERROCAL (2009): Wood color variation in sapwood and heartwood of *Tectona grandis* and its relationship with plantation characteristics, site and decay resistance. *Ann For Sci* (in press)
- MOYA, R. and D. PÉREZ (2007): Processing and marketing of teakwood products from fast-grown teak plantations in Costa Rica. 24-?, in *Abstracts products and marketing of teak*

- wood products of planted forest. Regional workshop products and marketing of teak wood products of planted forest, edited by NAIR, K.V. BHAT and V. ANITHA. September 2007. KFRI, Peechi, India.
- MOYA, R. and D. PÉREZ (2008): Effect of physical and chemical soil properties on physical wood characteristics of *Tectona grandis* plantations in Costa Rica. *J Trop Forest Sci* 20: 147-155.
- MOYA, R., D. PÉREZ and V. ARCE (2003): Wood density of *Tectona grandis* at two plantation spacings in Costa Rica. *J Trop Forest Prod* 9(1/2): 153-161.
- MURILLO, O. and Y. BADILLA (2004): Breeding teak in Costa Rica, pp 105–110, in IUFRO Forest Genetics Meeting Proceedings edited by NC State University, Charleston, NC,.
- NADGAUDA, R.S., S.V. KENDURKAR, V.M. and KULKARNI (2003) Teak tissue culture for improved productivity. ??-??, in Abstracts products and marketing of teak wood products of planted forest. regional workshop products and marketing of teak wood products of planted forest, edited by by NAIR, K.V. BHAT and V. ANITHA. September 2007. KFRI, Peechi, India.
- PANDE, P. K. and M. SINGH (2005): Inter-clonal, intra-clonal, and single tree variations of wood anatomical properties and specific gravity of clonal ramets of *Dalbergia sissoo* Roxb. *Wood Sci Tech* 39: 351-366.
- PHELPS, J.E., E.A. MCGINNES, H.E. GARRETT and G.S. COX (1983): Growth-quality evaluation of black walnut wood. Part II—color analyses of veneer produced on different sites. *Wood Fiber Sci* 15: 177–185.
- PÉREZ, D. and M. KANNINEN (2003): Heartwood, sapwood and bark content, and wood dry density of young and mature teak (*Tectona grandis*) trees grown in Costa Rica. *Silva Fennica* 37(1): 45-54.
- PÉREZ, D. and M. KANNINEN (2005): Stand growth scenarios for *Tectona grandis* plantations in Costa Rica. *Forest Ecol Manag* 210: 425-441.
- RAO, R. and S. SHASHIKALA (2003): Assessment of growth rate, basic density, heartwood content in select teak clones of CSO. pp 440–447. in Abstracts products and marketing of teak wood products of planted forest. Regional workshop products and marketing of teak wood products of planted forest, edited by NAIR, K.V. BHAT and V. ANITHA. September 2007. KFRI, Peechi, India.
- Resende MDV (2002b) Software Selegen-Reml/Blup. Embrapa Florestas, Colombo, 67 pp (Documentos, 77).
- RINK G. (1987): Heartwood color and quality variation in a young black walnut progeny test. *Wood Fiber Sci* 19(1): 93-99
- RIVERO J. and R. MOYA (2006): Propiedades físico-mecánicas de la madera de *Tectona grandis* L. f. (teca), proveniente de una plantación de ocho años de edad en Cochabamba, Bolivia. *Kurú: Revista Forestal* 3(9): 1-14.
- SARANPÄÄ, P. (2003): Wood density and growth. pp. ?? in *Wood quality and its biological basis*, edited by J.R. Barnett and G. Jeronimidis. Blackwell Publishing Ltd., Oxford, UK.

- SCHMINCKE, K.H (2000): Plantaciones de teca en Costa Rica: la experiencia de la empresa Precious Woods. *Unasyva* 201: 1-8
- SHARMA, R., D. SWAIN and A. K. MANDAL (2000): Estimates of genetic parameters from an open pollinated genetic test of teak (*Tectona grandis*). *J Trop Forest Sci* 2:44-48.
- SOTELO M. C., R. HERNANDEZ, J. BEAULIEU and J.C. WEBER (2008): Genetic variation in wood color and its correlations with tree growth and wood density of *Calycophyllum spruceanum* at an early age in the Peruvian Amazon. *Wood Fiber Sci* 39: 1-13.
- TAKATA, K. and Y. TERAOKA (2002): Genotypic effects on the variation of wood quality and growth rates in plantation forest made cutting cultivars of Japanese cedar. *J Wood Sci* 48:106-113.
- TEWARI, D.N. (1999): A monograph on teak (*Tectona grandis*). International Book Distrtors. Dehra Dun, India.
- THULASIDAS, P.K., K.M. BHAT and T. OKUMA (2006): Heartwood colour variation in home garden teak (*Tectona grandis*) from wet and dry localities of Kerala, India. *J Trop Forest Sci* 18: 51-54.
- VANCLAY, J.k., M. HENSON, M. and G. PALMER (2008): Color variation and correlations in *Eucalyptus dunnii* sawnwood. *J Wood Sci* 54: 431-435.
- VARGHESE, M., A. NICODEMUS, P.K. RAMTEKE, G. ANBAZHAGI, S.S. BENNET and K. SUBRAMANIAN (2000): Variation in growth and wood traits among nine populations of teak in Peninsular India. *Silvae Genetica* 49: 201-205.
- VÍQUEZ, E. and D. PÉREZ (2005): Effect of pruning on tree growth, yield, and wood properties of *Tectona grandis* plantations in Costa Rica. *Silva Fennica* 39: 381–390.
- ZOBEL, B.J. and J.B. JETT (1995): Genetics of wood production. Springer Verlag, Berlin, Germany
- ZOBEL, B.J. and J.P. VAN BUIJTENEN (1998): Wood Variation: its causes and control Springer Verlag, Berlin, Germany.

4. MARIN, D., MOYA, R. Application of ultrasound and Ciel L*a*b* color systems in genetic selection of fast growth *Tectona grandis* (L.f) clones. Kuru: Revista Forestal (a someter en los próximos dos meses)

8.3. Congresos internacionales

MOYA, R., BERROCAL, A., LEANDRO, L., 2008. Relation of wood color determined by Ciel L*a*b* color systems and its durability in wood of *Tectona grandis* form fast growth plantation in Costa Rica. En. Leandro, L. (ed). Libro de Resúmenes II Taller Latinoamericano de Ensayos no destructivos en productos de madera. 2-4 de diciembre de 2008. San José – Costa Rica. p.48.

ABSTRACT

A total of 23 teak forest plantations within ages between 7 and 15 years were selected in Costa Rica, covering a wide range of soil physical and chemical properties to study the relationship between wood color and soil properties. Wood color measurements were carried out using a portable Miniscan XE plus (Hunter Lab) and spectra reflectance was recorded according to the standardized CIELab chromaticity system. And *Trametes versicolor* and *Pycnoporus sanguineus* were utilized for testing of decay resistance of *Tectona grandis* wood. Results analysis shown that L* ranged from 46.8 to 80.9, a* from 1.9 to 13.6 and b* from 4.1 to 32.6 in the sapwood and heartwood. And it were found that the bests parameters to predicted decay resistance in *Tectona grandis* were L* and a* parameters of CIE Lab color systems. Wood with highest values of L* and a* significant (around 70-80 and 10-13 respectively) is lowest decay resistant. The b* parameters was not correlated with decay resistance for both fungi.

Keywords: tropical wood, non-destructive test, HunterLab, Costa Rica, non destructive test.

MARIN, D., MOYA, R., 2008. Application of ultrasound and Ciel L*a*b* color systems in genetic selection of fast growth *Tectona grandis* (L.f) clones. En. Leandro, L. (ed). Libro de Resúmenes II Taller Latinoamericano de Ensayos no destructivos en productos de madera. 2-4 de diciembre de 2008. San José – Costa Rica. p.51.

ABSTRACT

Tectona grandis has been widely planted in several tropical countries of Asia, America and Africa. Nowadays it is estimated about 6 million have been planted. However, many areas have felled in short rotation age, showing that the wood from these trees has been consider of lower mechanical properties and they are of different colors from de wood of those trees that grow up in the native forest of Asia. In the other hand, the industries that plant Teca have developed genetic improvement programs which look for results in good growing and quality features of the wood in this specie, including between the alternatives the clones selection. That is why in the current document it is showed the results of the heritability valuation from 22 teca's clones of 10 years old. The results show that the ultrasound speed went from 7083.33 m/s to 2090.40 m/s related to the colour variation which was in L varied from 49.44 to 80.60, in a* varied from 12.12 to 3.72 and in b* varied from 32.36 to 19.22. In addition it is showed the usage of the ultrasound and the colour measurement system CIE L *a*b COLOR SYSTEM as a tool to establish researches wich allow to choose the clones with the best values of resistance and wood colour, to establish the heritability grade of each parameter and also watch the behaviour of the elasticity module and the wood color related to the tree diameter.

Keywords: Stiffness, Costa Rica, non-destructive test, HunterLab, SylatestDUO.